



PIPE RACKING SYSTEM -JOINTS

ISO 9001/ ISO 14001 Certified

ADVANCED MECHATRONICS SOLUTIONS, INC www.ams-fa.com



PLASTIC JOINTS









Comprehensive Production from part manufacturing to assembly

COLORS

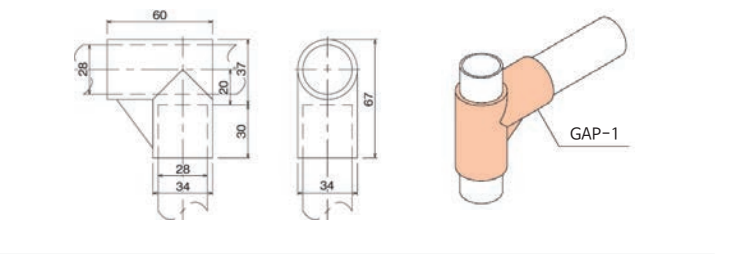
Ivory ● Gray ● Green ● Esd ●

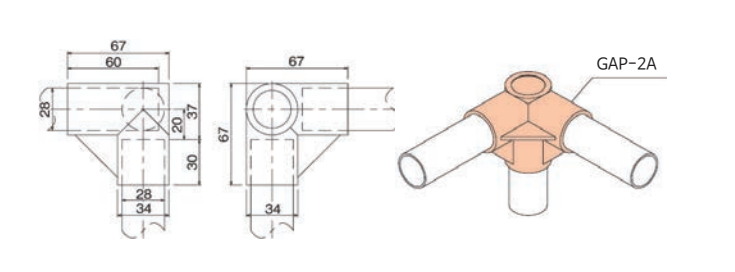
COLOR : ● Ivory ● Gray ● Green ● Esd

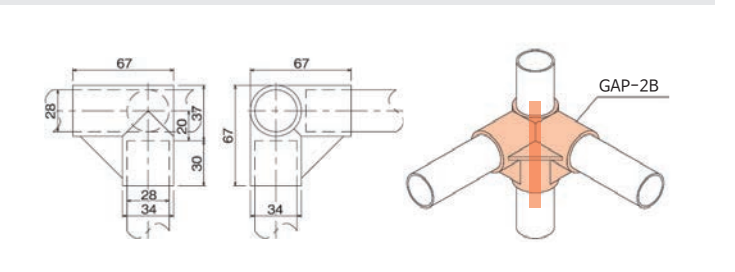
Unit : mm

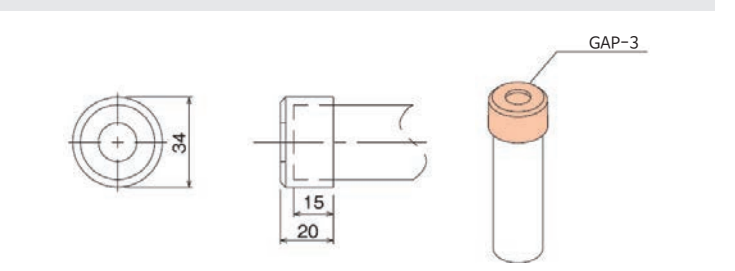
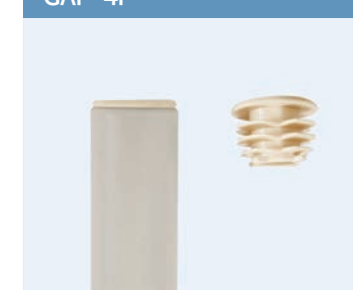
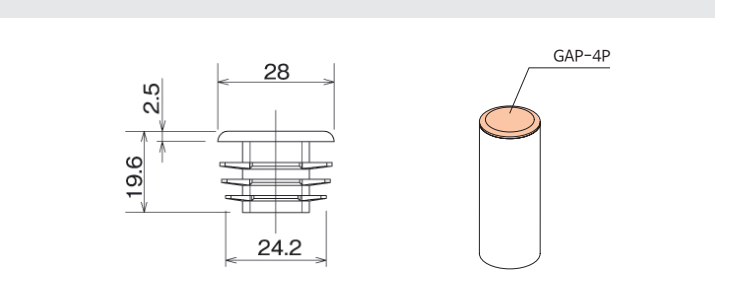
<p>GAP-1</p> 	<p>Plastic Joint</p> <table border="1"> <tr> <td>Material</td> <td>ASA</td> </tr> <tr> <td>Weight</td> <td>0.030kg</td> </tr> <tr> <td>Q'ty/Box</td> <td>150pcs</td> </tr> </table>	Material	ASA	Weight	0.030kg	Q'ty/Box	150pcs	
Material	ASA							
Weight	0.030kg							
Q'ty/Box	150pcs							
<p>GAP-2A</p> 	<p>Plastic Joint</p> <table border="1"> <tr> <td>Material</td> <td>ASA</td> </tr> <tr> <td>Weight</td> <td>0.045kg</td> </tr> <tr> <td>Q'ty/Box</td> <td>75pcs</td> </tr> </table>	Material	ASA	Weight	0.045kg	Q'ty/Box	75pcs	
Material	ASA							
Weight	0.045kg							
Q'ty/Box	75pcs							
<p>GAP-2B</p> 	<p>Plastic Joint (Through part)</p> <table border="1"> <tr> <td>Material</td> <td>ASA</td> </tr> <tr> <td>Weight</td> <td>0.048kg</td> </tr> <tr> <td>Q'ty/Box</td> <td>75pcs</td> </tr> </table>	Material	ASA	Weight	0.048kg	Q'ty/Box	75pcs	
Material	ASA							
Weight	0.048kg							
Q'ty/Box	75pcs							
<p>GAP-3</p> 	<p>Outer Cap</p> <table border="1"> <tr> <td>Material</td> <td>ASA</td> </tr> <tr> <td>Weight</td> <td>0.009kg</td> </tr> <tr> <td>Q'ty/Box</td> <td>900pcs</td> </tr> </table>	Material	ASA	Weight	0.009kg	Q'ty/Box	900pcs	
Material	ASA							
Weight	0.009kg							
Q'ty/Box	900pcs							
<p>GAP-4P</p> 	<p>Inner Cap</p> <table border="1"> <tr> <td>Material</td> <td>LDPE</td> </tr> <tr> <td>Weight</td> <td>0.003kg</td> </tr> <tr> <td>Q'ty/Box</td> <td>1500pcs</td> </tr> </table>	Material	LDPE	Weight	0.003kg	Q'ty/Box	1500pcs	
Material	LDPE							
Weight	0.003kg							
Q'ty/Box	1500pcs							

PLASTIC JOINTS

COLOR: ● Ivory ● Gray ● Green ● Esd

Unit : mm

GAP-4C/4S Inner Cap



Material	LDPE
Weight	0.003kg
Q'ty/Box	1500pcs

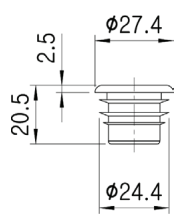
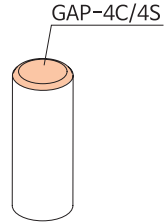



GAP-4R Rubber Cap

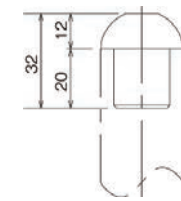
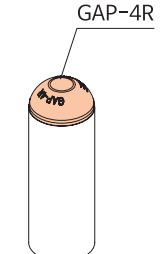

Material	TPU
Weight	0.009kg
Q'ty/Box	900pcs

* Color : BK

GAP-5 Plastic Joint Corner



Material	ASA
Weight	0.032kg
Q'ty/Box	150pcs

GAP-6 Label Holder

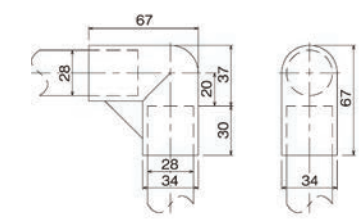
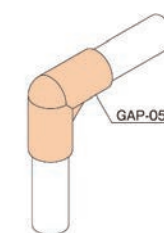

Material	ABS
Weight	0.005kg
Q'ty/Box	1200pcs

GAP-6B Label Holder

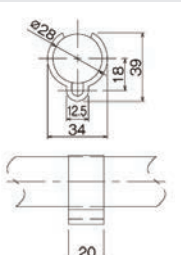
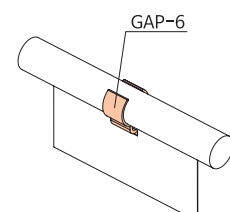

Material	ABS
Weight	0.005kg
Q'ty/Box	1200pcs



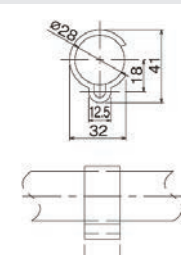
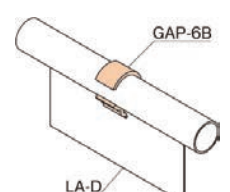

PLASTIC JOINTS

COLOR: ● Ivory ● Gray ● Green ● Esd

Unit : mm

GAP-7 Plastic Joint

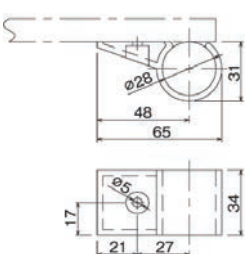
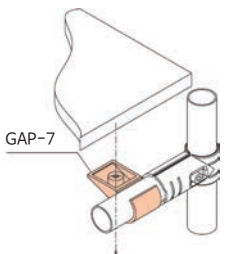

Material	ABS
Weight	0.011kg
Q'ty/Box	450pcs

GAP-8 Horizontal Holder



Material	ABS
Weight	0.005kg
Q'ty/Box	1200pcs

GAP-8FN Horizontal Holder (Flat Type)

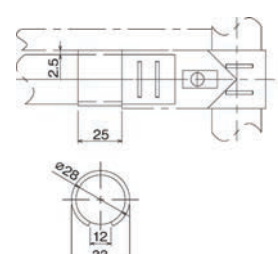
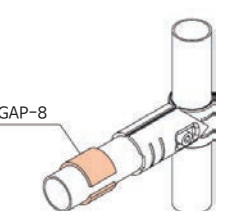

Material	ABS
Weight	0.005kg
Q'ty/Box	1200pcs



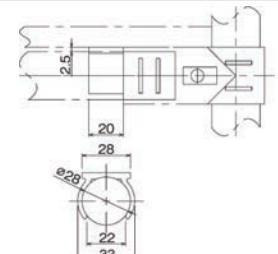
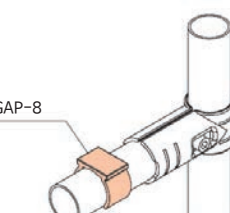

GAP-9C-07 Grip Bushing (Coating Pipe: Ø28×T0.7)

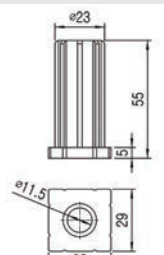
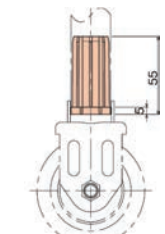

Material	NYLON66
Weight	0.016kg
Q'ty/Box	450pcs

* Color : BK





GAP-9C-09 Grip Bushing (Coating Pipe: Ø28×T0.9)

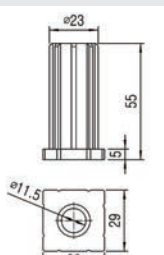
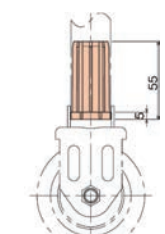

Material	NYLON66
Weight	0.016kg
Q'ty/Box	450pcs

* Color : BK





PLASTIC JOINTS

COLOR: ● Ivory ● Gray ● Green ● Esd

Unit : mm

GAP-9S-07 Grip Bushing (STS Pipe: $\varnothing 28 \times T0.7$)



Material	NYLON66
Weight	0.016kg
Q'ty/Box	450pcs

* Color : BK

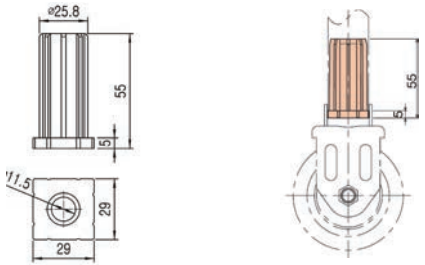

GAP-10R Plastic Joint (Right side handle)

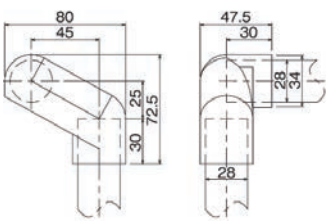
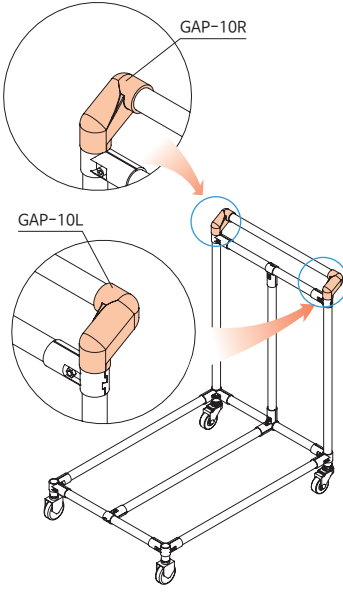

Material	ASA
Weight	0.042kg
Q'ty/Box	120pcs

GAP-10L Plastic Joint (Left side handle)



Material	ASA
Weight	0.042kg
Q'ty/Box	120pcs



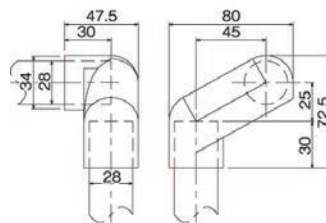
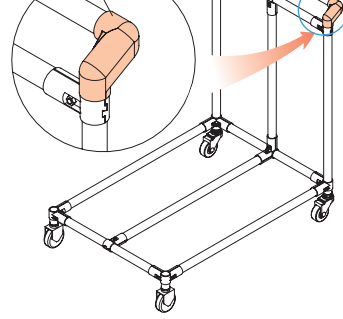

GAP-11 Taper Edge

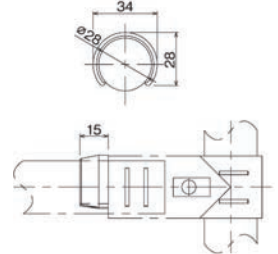
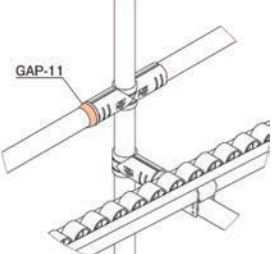

Material	ABS
Weight	0.005kg
Q'ty/Box	250pcs

When moving the box, GAP-11 can prevent from hanging





GAP-12 Sleeve (For GA-12S/17S/18S/24S/25S)

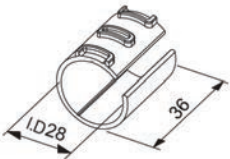

Material	PE
Weight	0.007kg
Q'ty/Box	600pcs

* Color : White





PLASTIC JOINTS

COLOR: ● Ivory ● Gray ● Green ● Esd

Unit : mm

GAP-13 Plastic Joint Corner

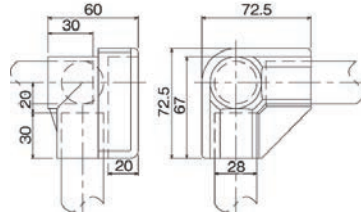
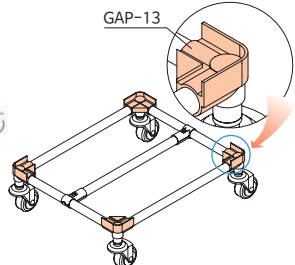

Material	ABS
Weight	0.059kg
Q'ty/Box	75pcs

GAP-14 Plastic Joint Corner Cushion Type



Material	ABS
Weight	0.075kg
Q'ty/Box	75pcs

GAP-15 Sheet Holder

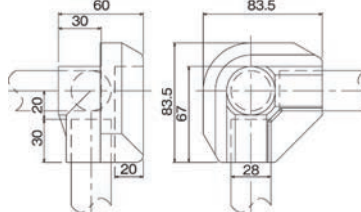
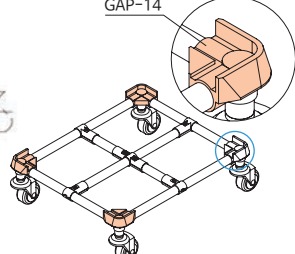

Material	ABS
Weight	0.003kg
Q'ty/Box	1500pcs

GAP-16 Plastic Joint

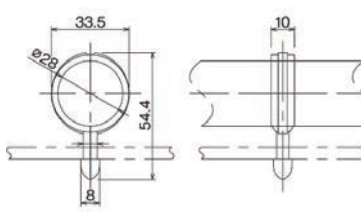
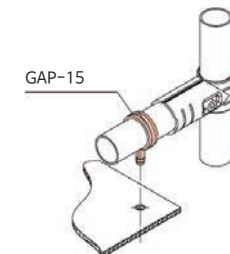

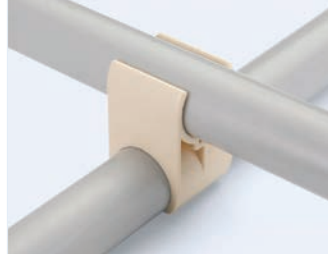
Material	ASA
Weight	0.018kg
Q'ty/Box	300pcs

GAP-17 Plastic Joint

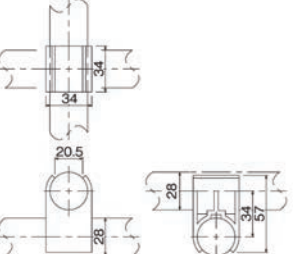
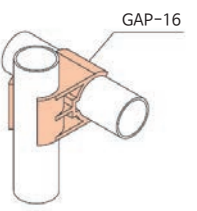

Material	ABS
Weight	0.014kg
Q'ty/Box	400pcs



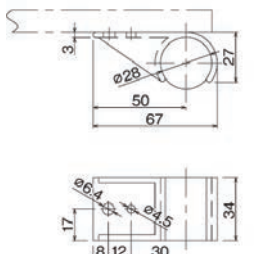
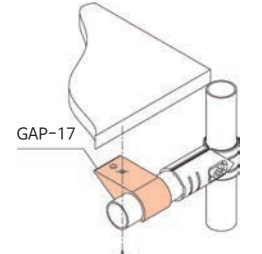

PLASTIC JOINTS

COLOR: ● Ivory ● Gray ● Green ● Esd

Unit : mm

GAP-18A Plastic Joint (Block one side)

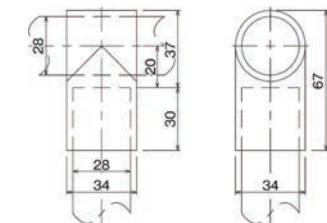
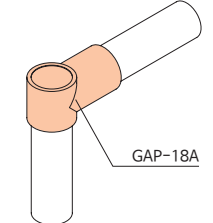

Material	ASA
Weight	0.023kg
Q'ty/Box	240pcs

GAP-18B Plastic Joint

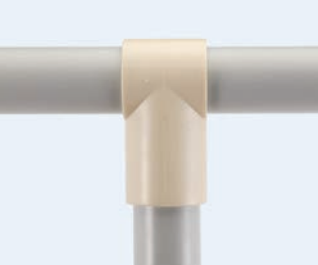

Material	ASA
Weight	0.022kg
Q'ty/Box	240pcs

GAP-19 Plastic Joint

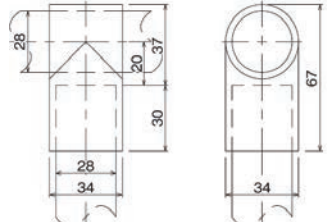
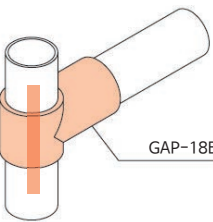

Material	ASA
Weight	0.009kg
Q'ty/Box	750pcs

GAP-20 Name Plate Holder

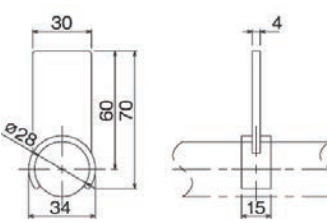
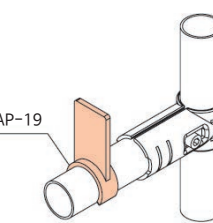

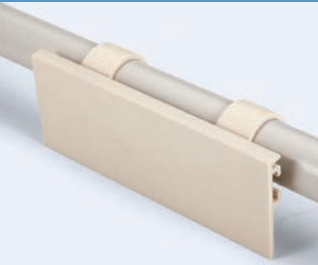
Material	ABS
Weight	0.006kg
Q'ty/Box	1200pcs

GAP-23 Plastic Joint

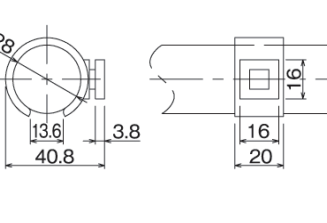
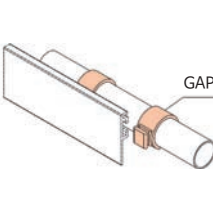
Include Bolt & Nut

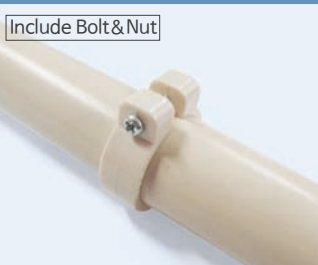

Material	ABS
Weight	0.020kg
Q'ty/Box	1500pcs

Bolt : M3x20
Nut : M3

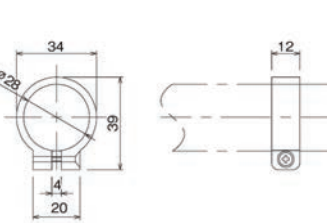
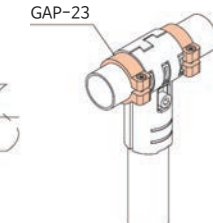



PLASTIC JOINTS

COLOR: ● Ivory ● Gray ● Green ● Esd

Unit : mm

GAP-24A Plastic Joint

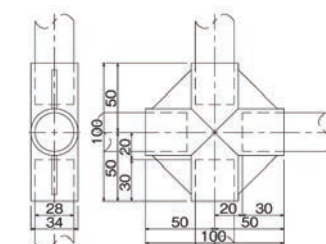
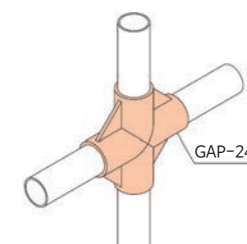

Material	ASA
Weight	0.060kg
Q'ty/Box	75pcs

GAP-24B Plastic Joint (Through part)



Material	ASA
Weight	0.057kg
Q'ty/Box	75pcs

GAP-25A Plastic Joint

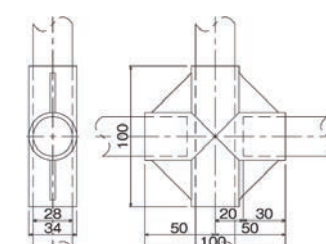
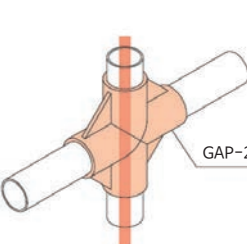

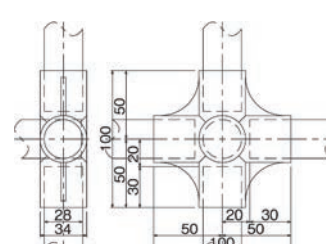
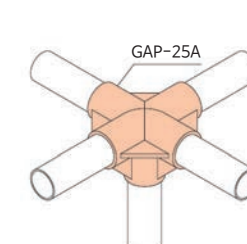

Material	ASA
Weight	0.075kg
Q'ty/Box	45pcs

GAP-25B Plastic Joint (Through part)

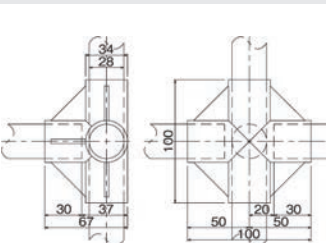

Material	ASA
Weight	0.072kg
Q'ty/Box	45pcs

GAP-26A Plastic Joint



Material	ASA
Weight	0.055kg
Q'ty/Box	75pcs



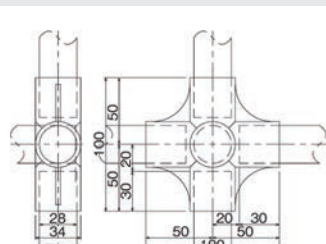
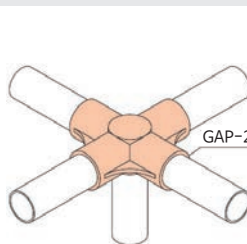

PLASTIC JOINTS

COLOR: ● Ivory ● Gray ● Green ● Esd

Unit : mm

GAP-26B Plastic Joint (Through part)



Material	ASA
Weight	0.054kg
Q'ty/Box	75pcs

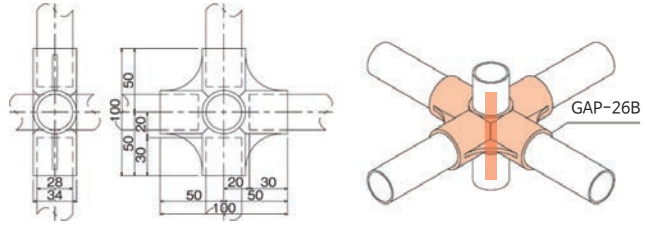

GAP-27A Plastic Joint



Material	ASA
Weight	0.035kg
Q'ty/Box	150pcs

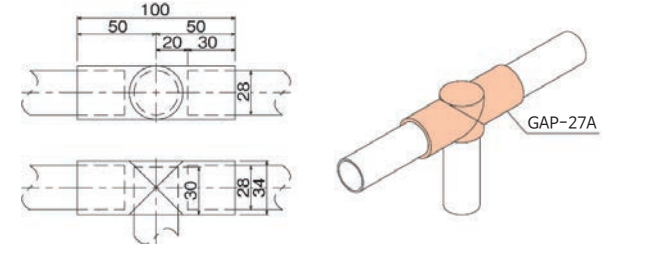

GAP-27B Plastic Joint (Through part)



Material	ASA
Weight	0.033kg
Q'ty/Box	150pcs

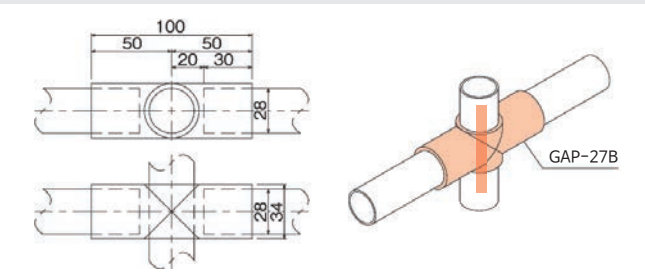

GAP-28A Plastic Joint



Material	ASA
Weight	0.046kg
Q'ty/Box	90pcs

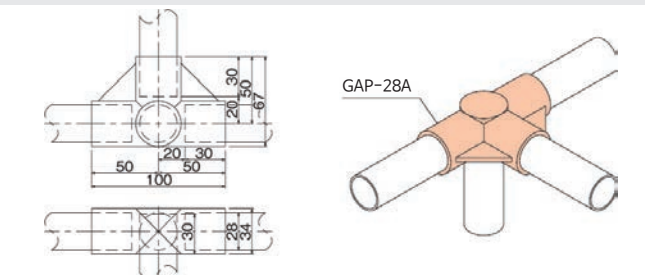

GAP-28B Plastic Joint (Through part)



Material	ASA
Weight	0.044kg
Q'ty/Box	90pcs

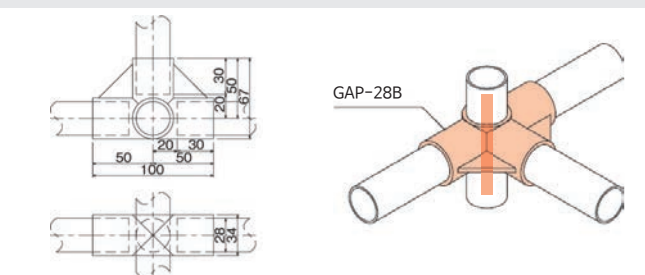

PLASTIC JOINTS

COLOR: ● Ivory ● Gray ● Green ● Esd

Unit : mm

GAP-29A Plastic Joint



Material	ASA
Weight	0.045kg
Q'ty/Box	90pcs

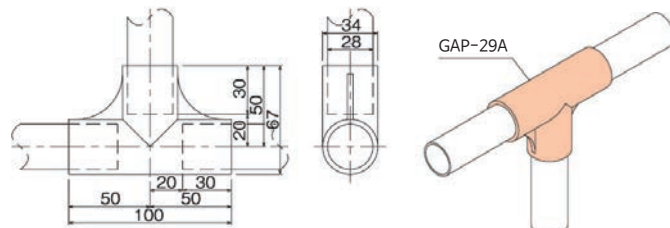

GAP-29B Plastic Joint (Through part)



Material	ASA
Weight	0.043kg
Q'ty/Box	90pcs

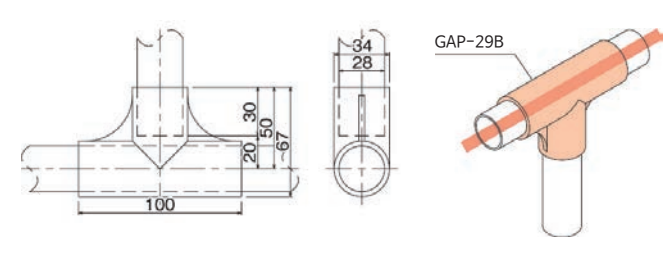

GAP-30A Plastic Joint



Material	ASA
Weight	0.026kg
Q'ty/Box	210pcs

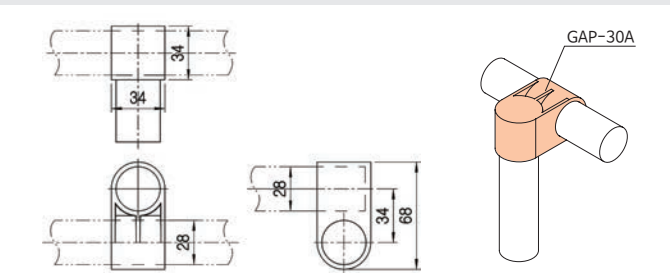

GAP-30B Plastic Joint



Material	ASA
Weight	0.025kg
Q'ty/Box	210pcs

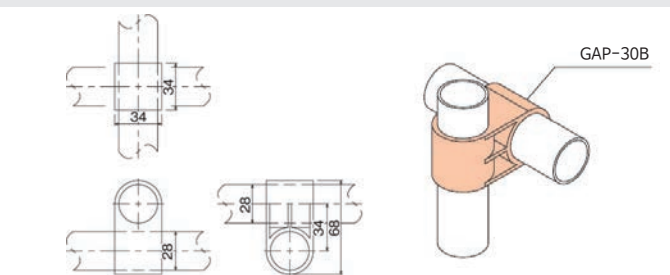

GAP-31 Plastic Joint



Material	ASA
Weight	0.020kg
Q'ty/Box	210pcs

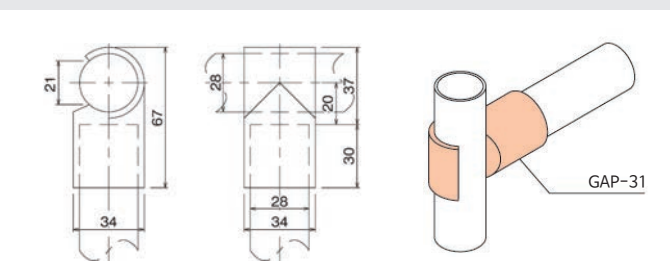

PLASTIC JOINTS

COLOR: ● Ivory ● Gray ● Green ● Esd

Unit : mm

GAP-34 Plastic Joint



Material	ASA
Weight	0.014kg
Q'ty/Box	500pcs

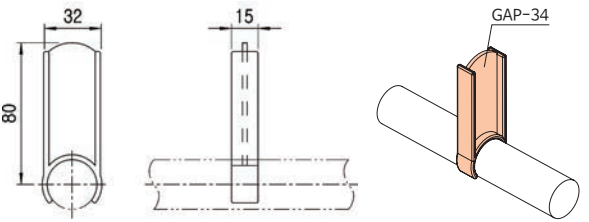

GAP-35 Plastic Joint

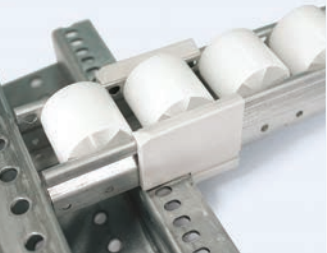

Material	NYLON66
Weight	0.015kg
Q'ty/Box	300pcs

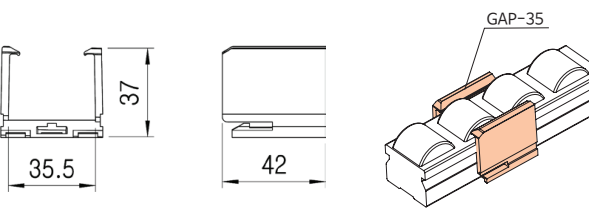

GAP-37A Plastic Joint

Sold separately Bolt & Nut



Material	ABS
Weight	0.011kg
Q'ty/Box	600pcs

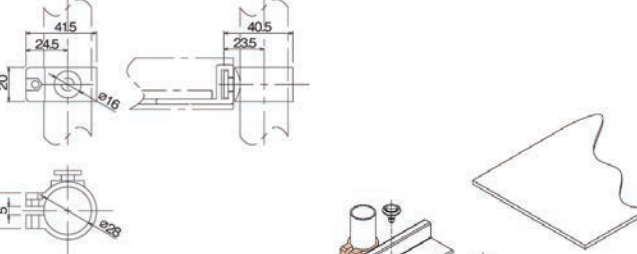

GAP-37B Plastic Joint

Sold separately Bolt & Nut

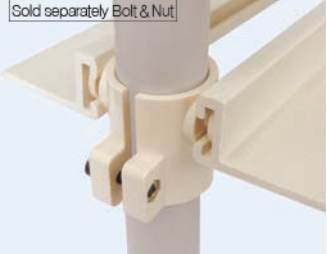

Material	ABS
Weight	0.019kg
Q'ty/Box	300pcs

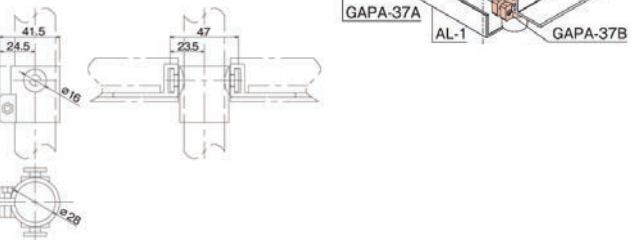

GAP-39 Plastic Joint



Material	PP
Weight	0.047kg
Q'ty/Box	120pcs

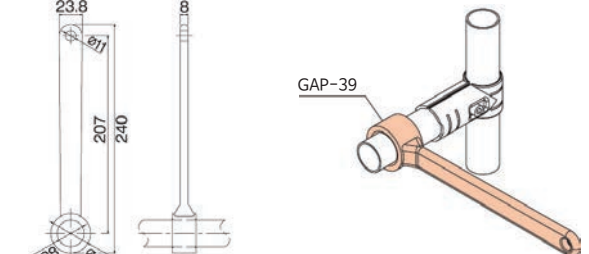

PLASTIC JOINTS

COLOR: ● Ivory ● Gray ● Green ● Esd

Unit : mm

GAP-40 Plastic Joint

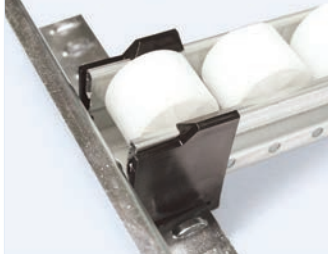

Material	NYLON66
Weight	0.045kg
Q'ty/Box	150pcs

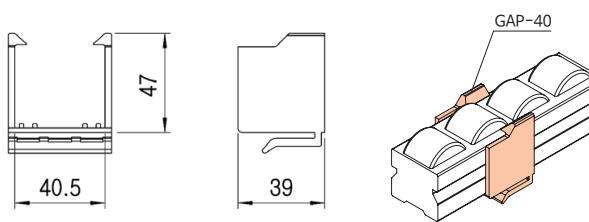

GAP-41 Plastic Joint



Material	ASA
Weight	0.030kg
Q'ty/Box	150pcs

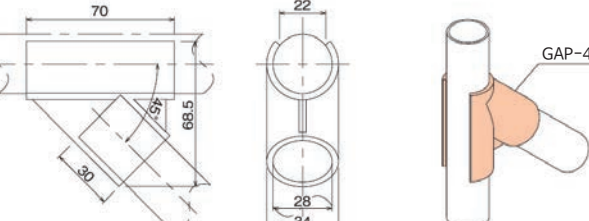

GAP-42 Plastic Joint

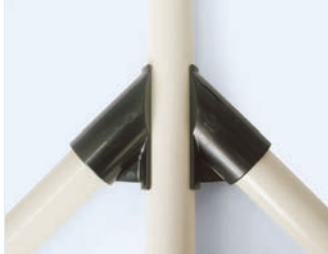

Material	ASA
Weight	0.045kg
Q'ty/Box	90pcs

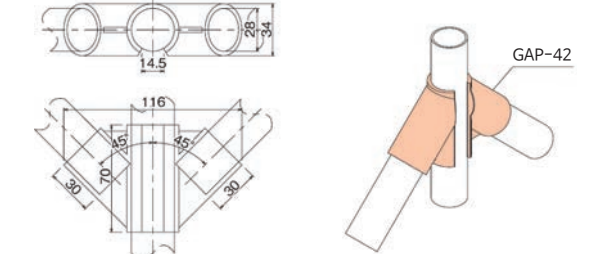

GAP-43 Plastic Joint



Material	NYLON6
Weight	0.028kg
Q'ty/Box	150pcs

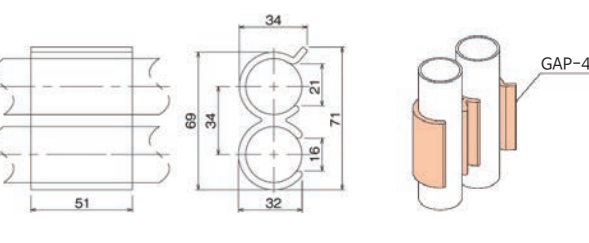

GAP-44 Sleeve (For GA-12S/17S/18S/24S/25S)



Material	PE
Weight	0.012kg
Q'ty/Box	200pcs

* Color : White

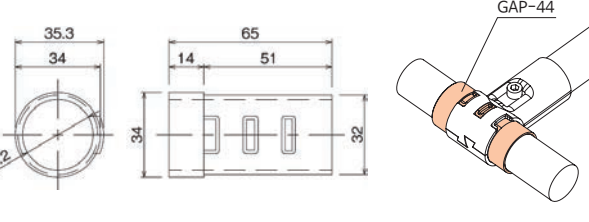

PLASTIC JOINTS

COLOR: ● Ivory ● Gray ● Green ● Esd

Unit : mm

GAP-45A Plastic Joint

Material	ASA
Weight	0.060kg
Q'ty/Box	75pcs

GAP-45B Plastic Joint (Through part)

Material	ASA
Weight	0.060kg
Q'ty/Box	75pcs

GAP-46 Plastic Joint

Material	ABS
Weight	0.013kg
Q'ty/Box	450pcs

GAP-47 Plastic Joint (Length adjustment)

Material	ABS
Weight	0.030kg
Q'ty/Box	180pcs

GAP-53 Plastic Joint

Material	ASA
Weight	0.014kg
Q'ty/Box	450pcs

PLASTIC JOINTS

COLOR: ● Ivory ● Gray ● Green ● Esd

Unit : mm

GAP-48 Roller Conveyor Holder (Single)

Material	ASA
Weight	0.013kg
Q'ty/Box	500pcs

GAP-49 Roller Conveyor Holder (Double)

Material	ASA
Weight	0.030kg
Q'ty/Box	150pcs

GAP-50 Roller Conveyor Cap (Without Bearing)

Material	POM
Weight	0.008kg
Q'ty/Box	1200pcs

GAP-51 Roller Conveyor Support

Material	POM
Weight	0.007kg
Q'ty/Box	1200pcs

GAP-52A Roller Conveyor Cap (With Bearing)

Material	ABS
Weight	0.013kg
Q'ty/Box	1500pcs

PLASTIC JOINTS

PLASTIC JOINTS

ADVANCED MECHATRONICS SOLUTIONS, INC

PLASTIC JOINTS

COLOR: ● Ivory ● Gray ● Green ● Esd

Unit : mm

GAP-54 Plastic Joint



Material	ASA
Weight	0.025kg
Q'ty/Box	150pcs

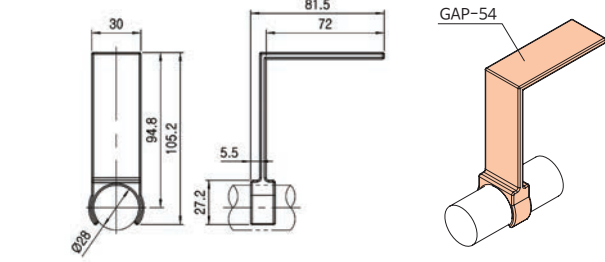

GAP-55 Name Plate Holder (Assembled NP-B)

Sold separately Bolt & Nut



Material	ABS
Weight	0.009kg
Q'ty/Box	750pcs

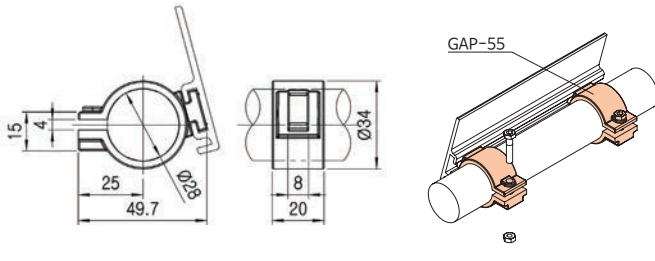

GAP-56 Sleeve (For GA-35S)

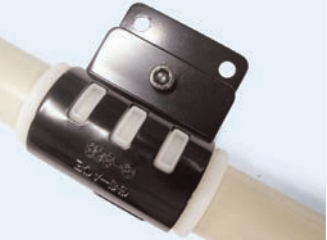

Material	PE
Weight	0.010kg
Q'ty/Box	300pcs

* Color : White

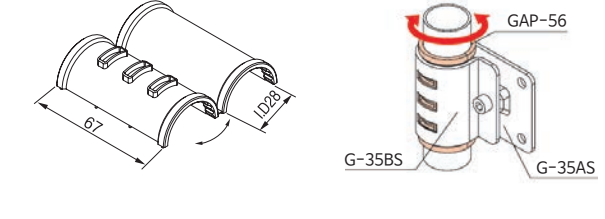

GAP-58 Name Plate Holder (Assembled NP-F)

*Prevent Name Plate from Rotating



Material	PVC
Weight	0.008kg
Q'ty/Box	900pcs

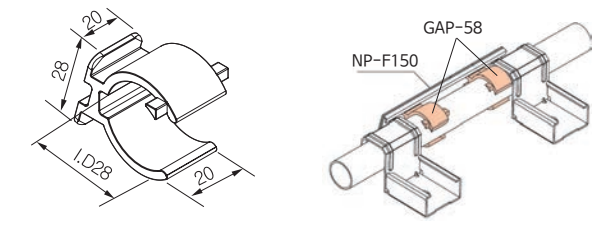

GAP-61 Plastic Joint



Material	ABS
Weight	0.015kg
Q'ty/Box	400pcs

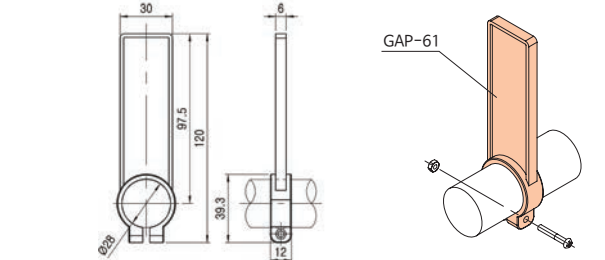

PLASTIC JOINTS

COLOR: ● Ivory ● Gray ● Green ● Esd

Unit : mm

GAP-64 Corner Support Joint

Registration patent



Material	ASA
Weight	0.165kg
Q'ty/Box	38pcs

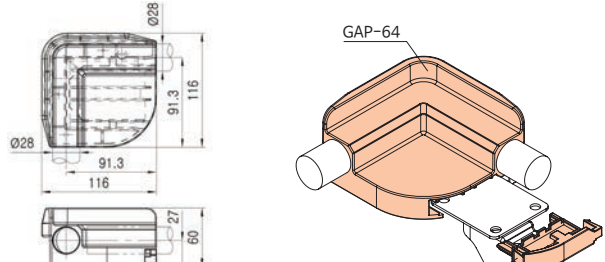

GAP-65 Corner Support Cap

Registration patent



Material	ABS
Weight	0.015kg
Q'ty/Box	400pcs

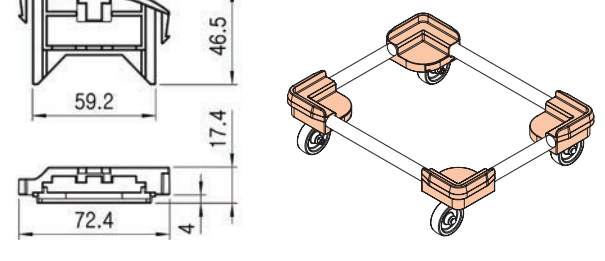

GAP-66 Plastic Joint



Material	ABS
Weight	0.022kg
Q'ty/Box	200pcs

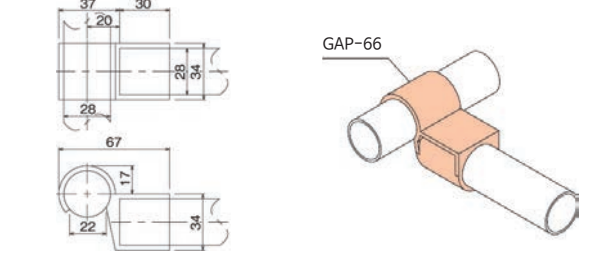

GAP-71 Plastic Joint



Material	ASA
Weight	0.029kg
Q'ty/Box	150pcs

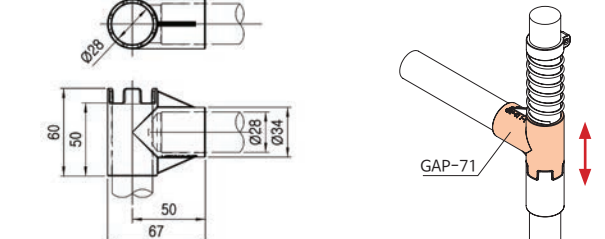

GAP-72 Plastic Joint



Material	ASA
Weight	0.014kg
Q'ty/Box	300pcs

After fixing GAP-71 into Pipe, disassembling GAP-72 and rotating, it could be fixed 90 degree

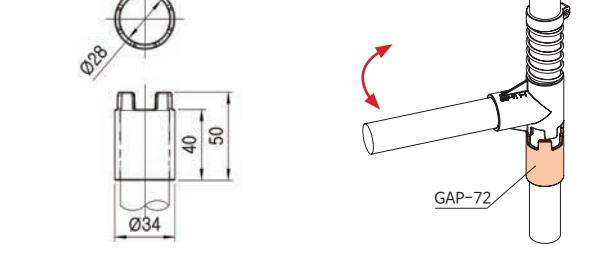

PLASTIC JOINTS

COLOR: ● Ivory ● Gray ● Green ● Esd

Unit : mm

NEW GAP-73 Plastic Latch

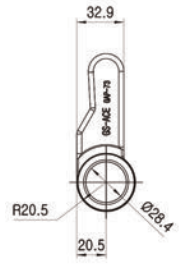
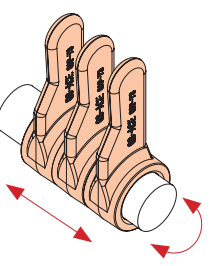

Material	TPU
Weight	0.033kg
Q'ty/Box	300pcs
* Color : Yellow	

NEW GAP-74A Plastic Latch



Material	TPU
Weight	0.028kg
Q'ty/Box	300pcs
* Color : Yellow	

NEW GAP-74B Plastic Latch

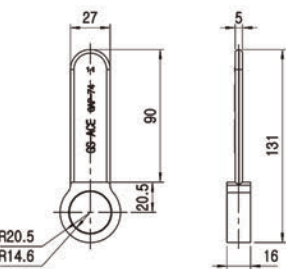
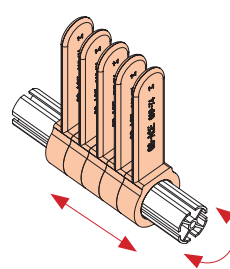

Material	TPU
Weight	0.028kg
Q'ty/Box	300pcs
* Color : Yellow	



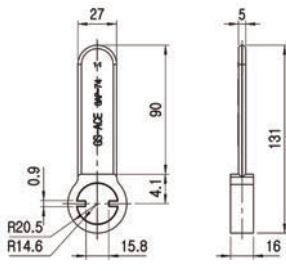
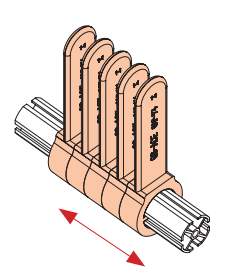

NEW GAP-75 Plastic Latch

Sold separately Bolt & Nut

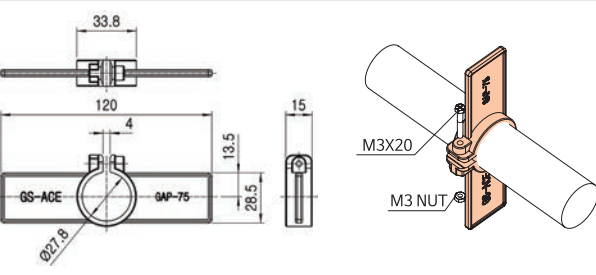
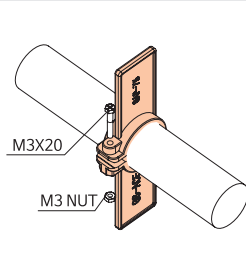

Material	ABS
Weight	0.012kg
Q'ty/Box	400pcs

 **AMS, INC.** Advanced Mechatronics Solutions, Inc.
10030 Via de la Amistad, San Diego, CA 92154 ☎ +1 (619) 661-5985 📠 +1 (619) 661-5995 @ ams@ams-fa.com

 **AMS do BRASIL** AMS Do Brasil Automacao Industrial LTDA de CV
Rua Laerte de Paiva, 344 Bairro Macuco Valinhos-SP-CEP13279.451 ☎ +5 (19) 849-5555 @ quote@ams-fa.com

 **AMS de MEXICO** AMS Factory Automation de Mexico SA de CV de CV
Polígono Buenavista -- Calle Cementera Lote 9, Mz 8 Ejido Buenavista - Querétaro, Qro. 76225
☎ +52 (442)312-0920 @ mexico@ams-fa.com

ADVANCED MECHATRONICS SOLUTIONS, INC www.ams-fa.com