

QUALITY IMPROVEMENT TOOL

Lineup Catalog



Play Video

Made by oneA JAPAN

Connection drawings

PMP shutter/PMP lamp/PMP rolling shutter

[APG-6,APG-RS3,APL-1]

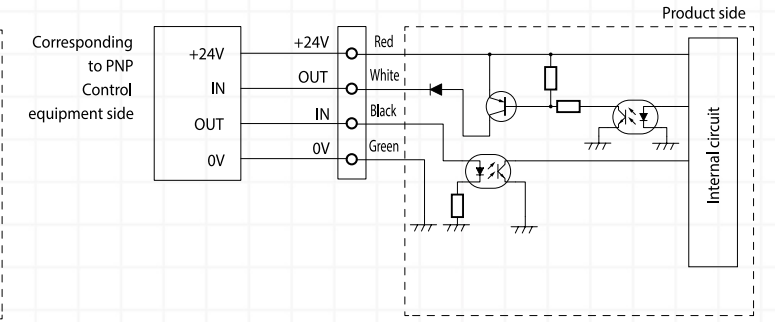
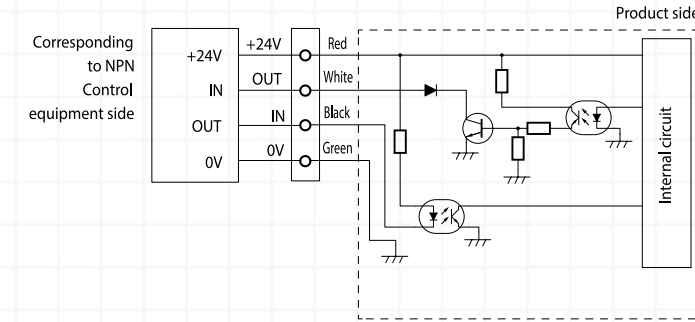

[APG-7]

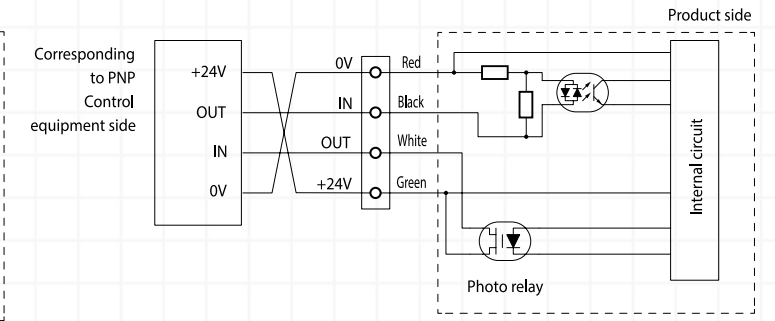
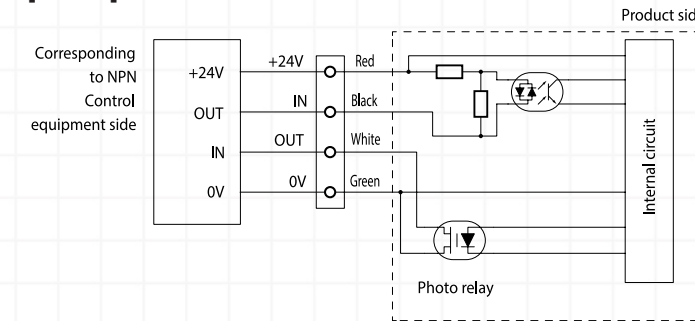

Basic operation

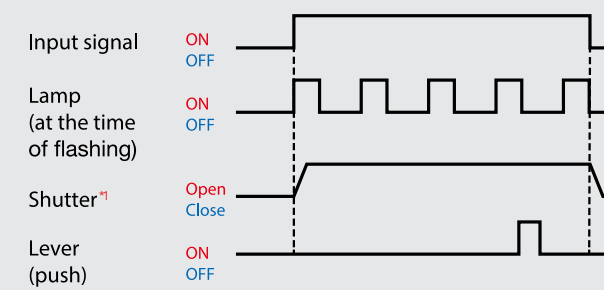

When the input signal is turned ON, the shutter opens and the lamp flashes (is lit). When the input signal is turned OFF, the shutter closes and the lamp goes out. When the lever (push) switch is operated, output turns ON (100ms) regardless of the state of the shutter.

*1) PMP shutter and PMP rolling shutter only.

Answerback mode { As for APG-7, the mode can be set by a remote controller (sold separately). As for others^{*1}, it can be set on the body. }

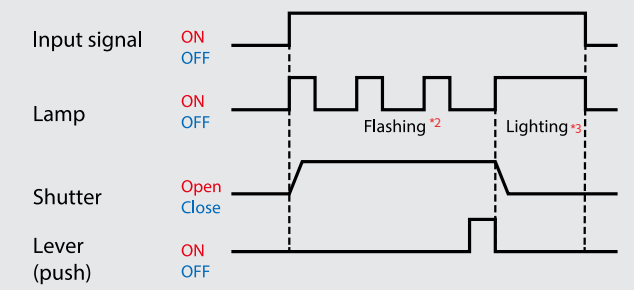

When the input signal is turned ON, the shutter opens and the lamp flashes (is lit). After that, when the lever (push) switch is turned ON, the shutter closes and the lamp is lit (flashes). When the input signal is turned OFF, the lamp goes out.

*1) As for APG-6, ver.5 or later is available.

*2) When the mode is set to "Lighting," the lamp is changed to "Flashing" by turning the lever (push) switch ON.

*3) The specifications of lamp lighting depend on model.



AMS, INC. 10030 Via de la Amistad, San Diego, CA 92154
T: +1 (619) 661-5985 F: +1 (619) 661-5995 E: ams@ams-fa.com

AMS Dynamics, Inc. 2979 Pacific Drive Suite A Norcross, GA 30071
T: +1 (770) 864-5394 F: +1 (678) 691-1847 E: infoATL@ams-fa.com

AMS do BRASIL Rua Laerte de Paiva, 344, Bairro Macuco, Valinhos -SP-CEP 13279.451
T: +55 (19) 849-5555 E: quote@ams-fa.com

AMS de MEXICO Polígono Buenavista -- Calle Cementera Lote 9, Mz 8 Ejido Buenavista - Querétaro, Qro. 76225
T: +52 (442) 312-0920 E: mexico@ams-fa.com

“PMP” series can prevent you from picking up the wrong parts while performing picking-up operation!

Before → After in the case of taking countermeasures in response to careless mistakes

Before ▶

Rushing with a picking list in one hand.
The speed in operation is slow and the possibility of mistakes is high!

After ▶

Also the series can be used as a countermeasure in response to process skips such as tool selection.

Everyone makes a Mistake!

Lamp indication and opening/closing of shutter prevents picking-up wrong components and eliminate mistakes completely!

INSTALLATION EXAMPLE

· Small parts (bolt, label, etc...)

· Common parts

· Large parts (harness, etc.)

System configuration drawing

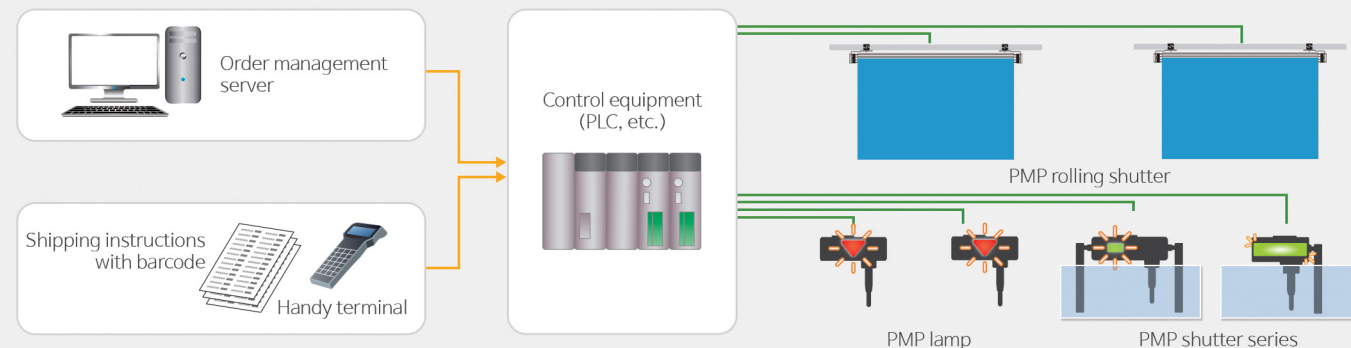

* Turning the input signal ON/OFF opens/closes the shutter and the lamp is turned ON/OFF.
* For connection to various wire-saving units, please contact us separately.

Adoption of lever switch

Superior durability and operations by magnetic sensor system

a Magnetic (hall element) Lever Switch is adopted. When the magnet tilts 15 degrees or more from the magnetic sensor, the open collector output is turned ON. The controller is resistant to dust/dirt, and built with a long life-span mechanical system.

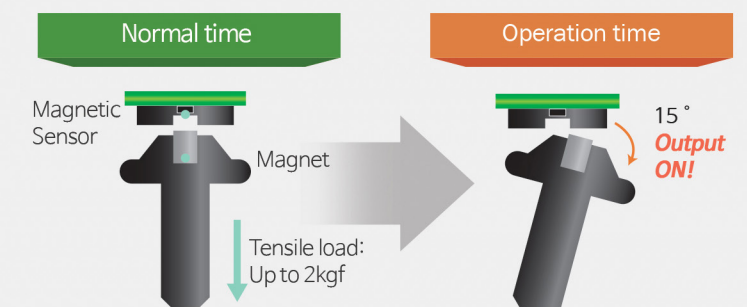

The same size and twice the torque!
 Picking mistake prevention shutter APG-7TL / 7TB new appearance!

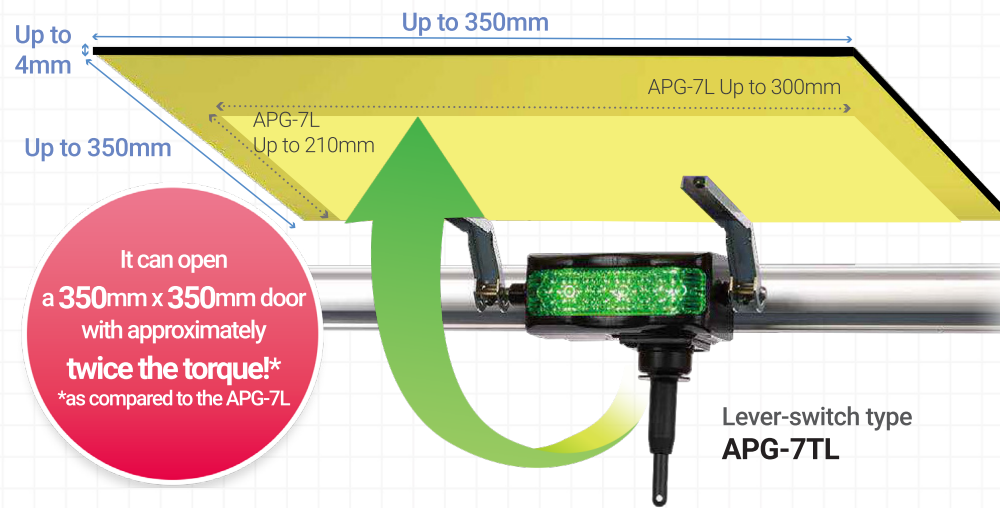

* Please contact us for shutter sizes over the recommended ones.

Prevent mistakes with its wide range of usability!
 Perfect for storage in both manufacturing and logistics!



It didn't work doors big enough to completely cover the opening



As it completely covers the opening, it works even better for mistake prevention

Specifications

PMP shutter APG-7T

Model	Levers witch type Push switch type	APG-7TL APG-7TB
Power source voltage		DC24V
Range of voltage used		20V~26.4V
Consumption current		Less than 0.4 (when moving the shutter) Less than 50mA (when on wait)
Current on star-up		Less than 0.6A
Input		Corresponding to contact point input or open collector (NPN/PNP) Input current: 5mA/ON voltage: 0.5V or below
Output		Open drain output (equivalent to open collector) Maximum current: 100mA
Illumination switch part indicating operation	Standard The mode can be set by an optional remote controller.	Flashing Flashing, Lighting, Unlit, Double flashing, Triple flashing
Illumination switch part indication color	Standard The mode can be set by an optional remote controller.	Green Green, Blue, Red, Yellow, Purple, Sky blue
Failure indicating movement		Red, Flashing
Setting of opening/closing angle	Standard The mode can be set by an optional remote controller.	Closing position: 0°/Opening position (open outward): 180° Open outward: 180°, 165°, 150°, 135°, 120°, 105°, 90° Open inward: -90°, -75° ¹⁾ /Closing position: 0°, 15°, 30°, 45°
Delay time setting	Standard The mode can be set by an optional remote controller.	1 (sec) 0, 0.5, 1, 2, 3, 4, 5, 7, 10 (sec)
Ambient temperature/humidity during use		0~50°C/30~85%RH (No dew condensation)
Ambient temperature/humidity for storage		-20~70°C/30~85%RH (No freeze and dew condensation)
Recommended shutter (size/mass)		W350×H350×T4mm (Max.) Less than 75g or below ²⁾
Torque value of shutter		16.5N·cm
Material (Corresponding to RoHS)	Body	Upper cover: PC-GF10/Body: SPCC (ZAM)
	Shaft	Drive side: SUS303
	Arm	SPCC (trivalent unichrome plating)
	Holder	Holder A: SUS304 CSP1/2H/Holder B: SUS304 2B
	Cable	VCTF 0.3mm ² ×4 cores, Connector with SMR-04V (manufactured by JST) yellow
Mass		APG-7TL: 270g/APG-7TB: 265g

¹⁾ When the shutter is opened inward, the push switch type is recommended.
²⁾ It is the value at the setting of the opening/closing angle of 0° or 180°(default). Available dimensions and mass vary depending on the shape, material and opening/closing angle.

Recommended shutter

APG-7TL/7TB

W350×H350 (MAX)
 Thickness: 4mm Maximum
 weight: 75g
 Material: corrugated plastic

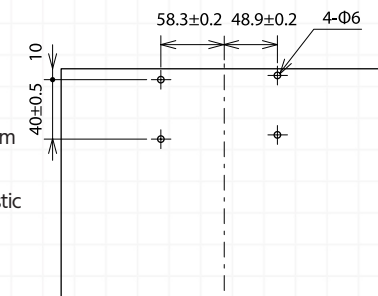

APG-7L/7B

W300×H210 (MAX)
 Thickness: 3mm Maximum
 weight: 30g
 Material: corrugated plastic

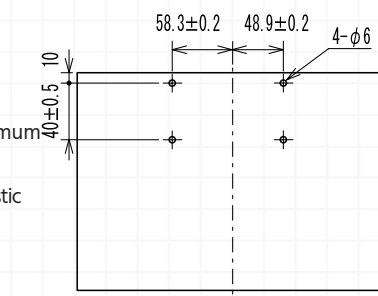

① Please contact us if you plan on using bigger shutters than recommended.

Features

- 1 ON/OFF of error output can be set by using a remote controller (sold separately).
- 2 The pipe mounting holder and arm portion is excellent in durability because they are made of metal.
- 3 The lamp color and type of actions can be set.
- 4 Adjustment of shutter opening/closing angle can be set at 7 steps (outward) and 2 steps (inward).
- 5 Adoption of high-torque motor realizes further downsizing, and mounting in a small space is possible.
- 6 Polycarbonate including glass in consideration of oil resistance has been adopted for the casing.
- 7 φ28 round pipe and aluminum pipe are available.

Bright lamps by optical design improve visibility.

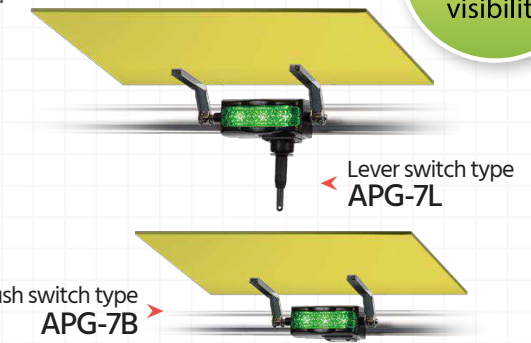

*No component that can be used as a door (corrugated plastic, etc.) is included.
 *Also two-support type is available (made-to-order).

Appearance dimensional drawing/name of each part (unit: mm)

[APG-7TL/APG-7L]

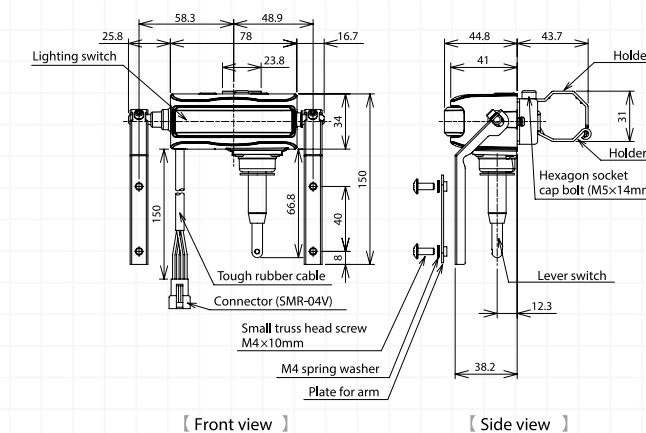

[APG-7TB/APG-7B]

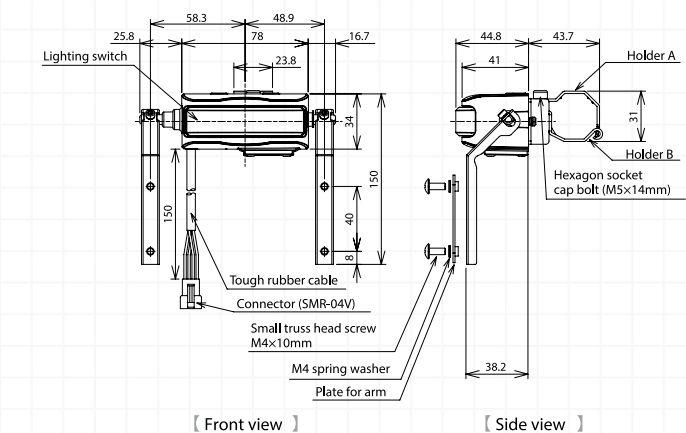

*Connecting connector: SMP-04V type (manufactured by JST)

Specifications

PMP shutter APG-7

Model	Levers witch type Push switch type	APG-7L APG-7B
Power source voltage		DC24V
Range of voltage used		20V~26.4V
Consumption current		0.4A
Current on star-up		0.6A
Input		Corresponding to contact point input or open collector (NPN/PNP) Input current: 5mA/ON voltage: 0.5V or below
Output		Open drain output (equivalent to open collector) Maximum current: 100mA
Illumination switch part indicating operation	Standard The mode can be set by an optional remote controller.	Flashing Flashing, Lighting, Unlit, Double flashing, Triple flashing
Illumination switch part indication color	Standard The mode can be set by an optional remote controller.	Green Green, Blue, Red, Yellow, Purple, Sky blue
Failure indicating movement		Red, Flashing
Setting of opening/closing angle	Standard The mode can be set by an optional remote controller.	Closing position: 0°/Opening position (open outward): 180° Open outward: 180°, 165°, 150°, 135°, 120°, 105°, 90° Open inward: -90°, -75° ¹⁾ /Closing position: 0°, 15°, 30°, 45°
Delay time setting	Standard The mode can be set by an optional remote controller.	1 (sec) 0, 0.5, 1, 2, 3, 4, 5, 7, 10 (sec)
Ambient temperature/humidity during use		0~50°C/30~85%RH (No dew condensation)
Ambient temperature/humidity for storage		-20~70°C/30~85%RH (No freeze and dew condensation)
Recommended shutter (size/mass)		W300×H210×T3mm (Max.) 30g or below ²⁾
Torque value of shutter		8.2N·cm
Material (Corresponding to RoHS)	Body	Upper cover: PC-GF10/Body: SPCC (ZAM)
	Shaft	Drive side: SUS303
	Arm	SPCC (trivalent unichrome plating)
	Holder	Holder A: SUS304 CSP1/2H/Holder B: SUS304 2B
	Cable	VCTF 0.3mm ² ×4 cores, Connector with SMR-04V (manufactured by JST)
Mass		Lever switch type: 260g/Push switch type: 250g

¹⁾ When the shutter is opened inward, the push switch type is recommended.
²⁾ It is the value at the setting of the opening/closing angle of 0° or 180°(default). Available dimensions and mass vary depending on the shape, material and opening/closing angle.

Remote controller dedicated for setting

Various settings such as lamp color and type of actions, and opening/-closing angles of shutter, ON/OFF of error output are made by remote control (sold separately).



Model	APG-RM1
Communication method	Infrared ray
Setting distance/angle	50cm/30°
Dimensions	W66×H205×D23.5mm
Mass	150g (dry-cell batteries not included)
Battery in use	Size AA alkaline battery×2 (sold separately)

Features

- 1 This shutter can be used for Pokayoke for a large entrance that cannot be handled by the conventional PMP shutter.
- 2 As the shutter part does not project forward, the shutter can be used even in a picking area with narrow passageways.
- 3 The screen part can be processed by customers to change the size for a small entrance.
- 4 The screen part can be separated from the control part, and each part can be installed individually.

Installation of control part suitable for the site

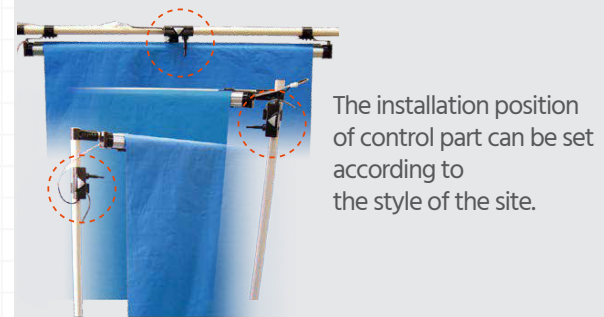

The installation position of control part can be set according to the style of the site.

*Extension code separately sold (part No: USP-070, length: 1,000mm) is required.

Appearance dimensional drawing/name of each part (unit: mm)

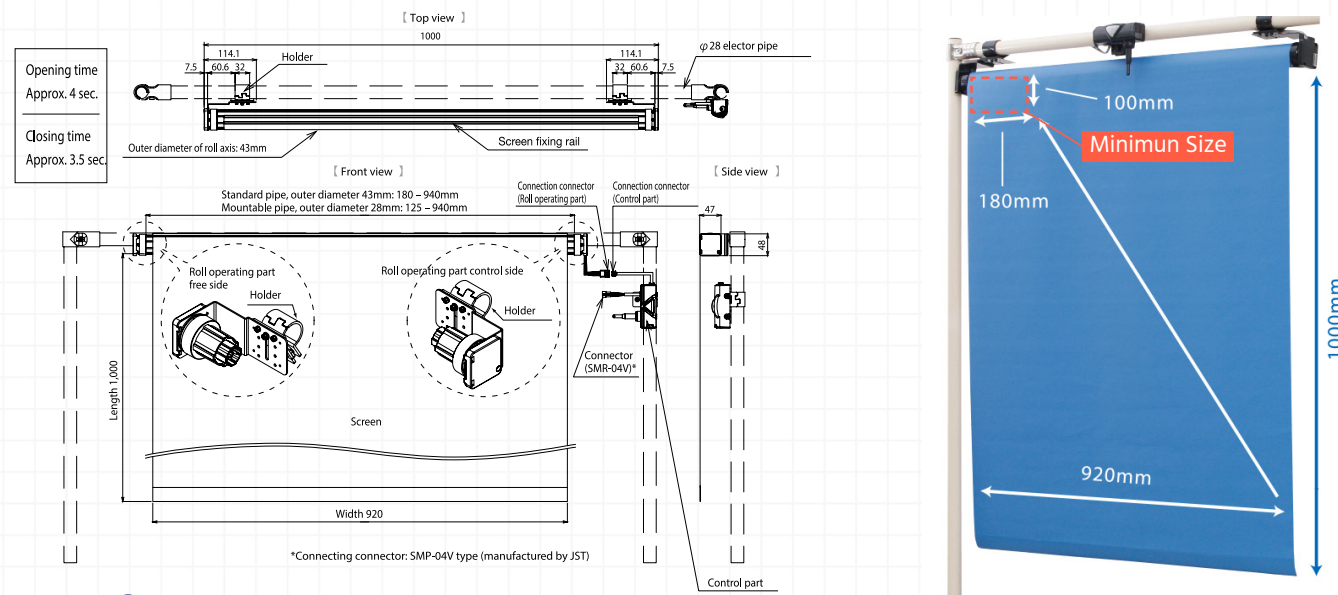

Specifications

PMP Rolling Shutter APG-RS3

Model	NPN Specifications		PNP Specifications	
	Lever switch type	Set part No: APG-RS3/control part: APG-RS31/roll operating part: APG-RS32	Set part No: APG-RS3-PN/control part: APG-RS31-PN/roll operating part: APG-RS32	Set part No: APG-RS3-PN-B/control part: APG-RS31-PN-B/roll operating part: APG-RS32
Power source voltage	DC24V			
Range of voltage used	20V~26.4V			
Consumption current	0.4A			
Current on start-up	0.6A			
Input	Corresponding to contact point input or open collector (NPN/PNP) Input current: 5mA/ON voltage: 0.5V or below			
Output	Output of NPN transistor/open collector Maximum current: 100mA		Output of PNP transistor/open collector Maximum current: 100mA	
Illumination switch part Indicating operation	In green, lighting or flashing setting available/when setting: high-speed flashing in blue			
Failure indicating movement	Flashing in red			
Delay time setting	0 [default], 0.5, 1, 3 (sec)			
Ambient temperature/humidity during use	0~50°C/30~85%RH (No dew condensation)			
Ambient temperature/humidity for storage	-20~70°C/30~85%RH (No freeze and dew condensation)			
Material (Corresponding to RoHS)	Body	Support for roll operating part: SPCC/control part: PC-GF10		
	Shaft on roll operating part control side	SUS303		
	Roll axis	Standard pipe, outer diameter 43mm, length 940mm, part No: GFF-200, Green Frame G (manufactured by SUS Corporation), aluminum Mountable pipe, outer diameter 28mm, part No: GFF-000, Green Frame (manufactured by SUS Corporation), aluminum		
	Screen fixing rail	Part No: GFA-805G, Frame Guard G (manufactured by SUS Corporation)		
Screen	PLYCANVAS E-2525 (manufactured by Ryoko Plastic Co., Ltd.) (Fire safety certificated No. F-05024), thickness 0.25mm ² (Dimensions: MAX width 920×length 1000mm/thickness: MAX 0.25mm/Mass: MAX 300g)			
Cable	Control part: VCTF0.3mm ² ×4 cores with a connector SMR-04V (manufactured by JST), connecting wire (UL1061, AWG26), L = 150mm Roll operating part control side: connecting wire (UL2468, AWG26), L = 150mm			
Mass	Roll operating part free side: 285g/roll operating part control side: 332g/screen part: 1020g Control part lever switch type: 205g/control part push switch type: 195g			

*1) NPN-spec push switch type, PNP-spec lever switch type and push switch type are made-to-order.

*2) When purchasing separately, please use the product equivalent to the above.

Features

- 1 As for the lever switch type, both lever switch and push switch styles can be used by setting.(The default is the lever switch type before shipment).
- 2 The ▼ shape of the lamp (push switch part) can prevent improper picking on the upper and lower shelves where the incidence rate is high.
- 3 The LED lighting lamp colors green and red, and lighting or flashing can be set.
- 4 The answerback mode* function can further improve the accuracy of picking operation.

*Answerback mode is a function to maintain the operation with another lamp action until the OFF signal is received from the upper controller after operation of the lever/push switch.

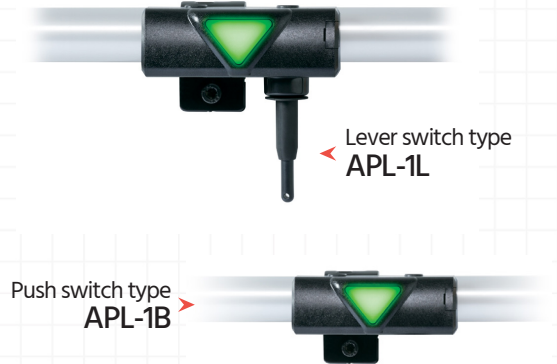

Appearance dimensional drawing/name of each part (unit: mm)

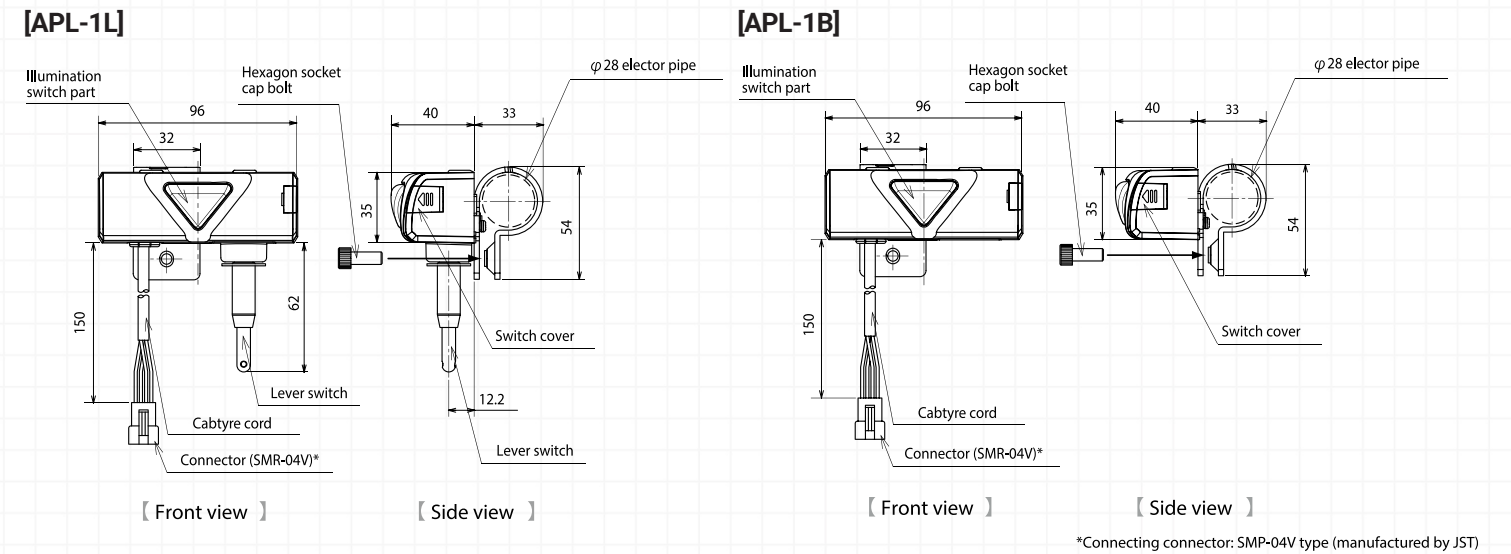

Specifications

PMP lamp APL-1

Model	NPN Specifications		PNP Specifications	
	Lever switch type	APL-1L	APL-1L-PN ^{*1}	APL-1B-PN ^{*1}
Power source voltage	DC24V			
Range of voltage used	20V~26.4V			
Consumption current	25mA			
Input	Corresponding to contact point input or open collector (NPN/PNP) Input current: 5mA/ON voltage: 0.5V or below			
Output	Output of NPN transistor/open collector Maximum current: 100mA		Output of PNP transistor/open collector Maximum current: 100mA	
Illumination switch part Indicating operation	In green, lighting or flashing setting available (lamp cover part)			
Ambient temperature/humidity during use	0~50°C/30~85%RH (No dew condensation)			
Ambient temperature/humidity for storage	-20~70°C/30~85%RH (No freeze and dew condensation)			
Material (Corresponding to RoHS)	Body	Upper cover: PC-GF10/body: SPCC(ZAM)		
	Roll axis	SPCC (cation electrodeposition coating)		
	Screen fixing rail	VCTF 0.3mm ² ×4 cores, Connector with SMR-04V (manufactured by JST)		
Mass	Lever switch type: 198g/Push switch type: 188g			

*1) PNP specifications are made-to-order.