



# PIPE RACKING SYSTEM -ROLLER TRACKS

ISO 9001/ ISO 14001 Certified

ADVANCED MECHATRONICS SOLUTIONS, INC [www.ams-fa.com](http://www.ams-fa.com)



# ROLLER TRACKS



Comprehensive Production from part manufacturing to assembly

GP-25 Series, GP-35 Series, GP-40 Series, GP-60 Series, GP-70 Series, GP-85 Series, GP-100 Series, Mounting Bracket

### ROLLER TRACK NUMBERING SYSTEM

**GP 40 36 A**

**SERIES/FRAME SIZE** | **PITCH** | **ROLLER TYPE**

- A: ROUND
- B: FLAT
- C: FLANGE
- SR: STS COVERED ROLLER
- D: LARGE
- HA: TAPER
- M: MULTI
- BF: FLEXIBLE
- S: SLIM

**ROLLER COLOR** WH: White ● GR: GRAY ● BK: BLACK ● YL: YELLOW ●

## SPECIFICATION

Unit : mm

Series	Part No.	Body Material (mm)	Load Capacity (Kg-f)	Roller Diameter (mm)	Shaft Diameter (mm)	Roller Pitch (mm)	Slope (°)	Roller Color				ESD		Standard Length
								WH	GR	BK	YL	BK	GR	

### Silent Roller Track

25 Series	GPR2528A	AL	60	Ø25	Ø3	28.57	1.5°	○	○						3MT/4MT
40 Series	GPR4040A	GI/AL	150	Ø34	Ø4	40	2.0°	○	○			○			3MT/4MT
	GPR4040B					○		○		○					
	GPR4055C					○		○		○					
	GPR4040SR							○							
60 Series	GPR6016S	GI/AL	100	Ø15	Ø4	16.67	2.5°	○	○			○		3MT/4MT	
	GPR6033B		150	Ø30	Ø4	33.33		○	○		○				
	GPR6033HA							○							
70 Series	GPR7042B	AL	200	Ø34	Ø5	42	3.5°					○		3MT/4MT	
	GPR7021BFS-2			Ø17.6		21		-				○			
85 Series	GPR8523S	GI/AL	300	Ø20.5	Ø3.5	22.5	1.5°	○		○		○		4MT	
	GPR8545B					○			○		○				
	GPR8545HA					○					○				
	GPR8545SR					○									
100 Series	GPR1021BFS	AL	250	Ø17.6	Ø5	21	-					○		2MT/3MT	

### Standard Roller Track

35 Series	GP3533B	GI	100	Ø28	Ø3	33.33	2.5°	○	○	○	○	○			3MT/4MT
40 Series	GP4036A	GI	150	Ø34	Ø4	36	2.0°	○		○		○			3MT/4MT
	GP4036B					○			○		○				
	GP4040A					○			○		○				
	GP4040B					○			○		○				
	GP4050C					○			○		○				
	GP4050D					○			○		○				
60 Series	GP6016S	GI	100	Ø15		16.67	2.5°	○	○			○		3MT/4MT	
	GP6033B		150	Ø30	Ø4	33.33		○	○		○				
	GP6033HA							○							
70 Series	GP7050BF	GI	200	Ø34	Ø5	50	3.5°				○	○		3MT/4MT	
85 Series	GP8525M	GI	300	Ø34	Ø5	25	2.5°	○		○		○		3MT/4MT	
	GP8543B			Ø40		43		○		○					
	GP8550SR			Ø43		Ø3.5		50	1.5°	○					

### STS COVERED ROLLER TRACK

40 Series	GPR4040SR	GI/AL	150	Ø34	Ø4	40	2.0°	○							3MT/4MT
85 Series	GPR8545SR	GI/AL	300	Ø43	Ø3.5	45	1.5°	○							2MT
	GP8550SR	GI	300			50		○							

### Universal Roller Track

40 Series	UR4050	AL	100	Ø43	Ø4	50	2.5°		○			○			3MT
60 Series	UR6067		200	Ø60	Ø5	66.7	3.0°		○			○			2MT

## GI-BODY SILENT ROLLER TRACK

Unit : mm

<b>GPR4040A/B-GI</b>	Silent Roller, Pitch: 40	
	<b>Material</b>	Body : GI
		Roller : PE
	<b>Q'ty/Bundle</b>	10ea

<b>GPR8545B-GI</b>	Silent Roller, Pitch: 45	
	<b>Material</b>	Body : GI
		Roller : PE
	<b>Q'ty/Bundle</b>	4ea

<b>GPR4055C-GI</b>	Silent Roller, Pitch: 55	
	<b>Material</b>	Body : GI
		Roller : PE
	<b>Q'ty/Bundle</b>	10ea

<b>GPR8545HA-GI</b>	Silent Roller, Pitch: 45	
	<b>Material</b>	Body : GI
		Roller : PE
	<b>Q'ty/Bundle</b>	4ea

<b>GPR6016S-GI</b>	Silent Roller, Pitch: 16	
	<b>Material</b>	Body : GI
		Roller : PE
	<b>Q'ty/Bundle</b>	10ea

<b>GPR6033B-GI</b>	Silent Roller, Pitch: 33	
	<b>Material</b>	Body : Aluminum
		Roller : PE
	<b>Q'ty/Bundle</b>	6ea

<b>GPR8523S-GI</b>	Silent Roller, Pitch: 22.5	
	<b>Material</b>	Body : GI
		Roller : PE
	<b>Q'ty/Bundle</b>	4ea

## AL-BODY SILENT ROLLER TRACK

Unit : mm

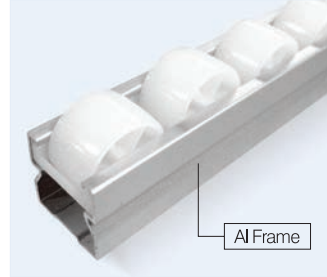
<b>GPR2528A-AL</b>	Silent Roller, Pitch: 28.6	
	<b>Material</b>	Body : Aluminum
		Roller : PE
	<b>Q'ty/Bundle</b>	10ea

<b>GPR6033B-AL</b>	Silent Roller, Pitch: 33	
	<b>Material</b>	Body : Aluminum
		Roller : PE
	<b>Q'ty/Bundle</b>	6ea

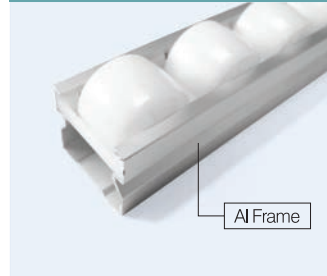
<b>GPR4040A/B-AL</b>	Silent Roller, Pitch: 40	
	<b>Material</b>	Body : Aluminum
		Roller : PE
	<b>Q'ty/Bundle</b>	10ea

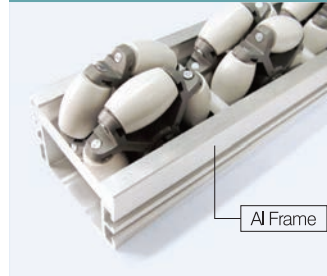
<b>UR6067-AL</b>	Universal Roller, Pitch: 67	
	<b>Material</b>	Body : Aluminum
		Roller : Acetal
	<b>Q'ty/Bundle</b>	4ea

<b>GPR4055C-AL</b>	Silent Roller, Pitch: 55	
	<b>Material</b>	Body : Aluminum
		Roller : PE
	<b>Q'ty/Bundle</b>	10ea

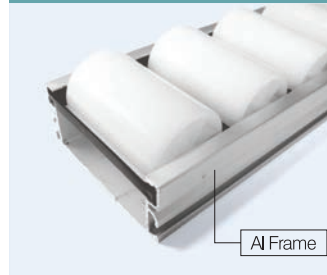
<b>GPR7042B-AL</b>	Silent Roller, Pitch: 42	
	<b>Material</b>	Body : Aluminum
		Roller : PE
	<b>Q'ty/Bundle</b>	6ea

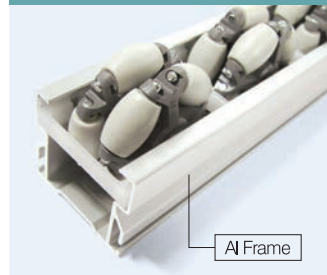
<b>UR4050-AL</b>	Universal Roller, Pitch: 50	
	<b>Material</b>	Body : Aluminum
		Roller : PE
	<b>Q'ty/Bundle</b>	6ea

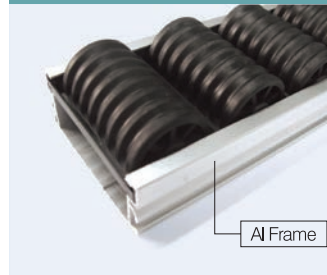
<b>GPR7042BF-AL</b>	Silent Roller, Pitch: 42	
	<b>Material</b>	Body : Aluminum
		Roller : TPV (ESD), Black
	<b>Q'ty/Bundle</b>	6ea

<b>GPR6016S-AL</b>	Silent Roller, Pitch: 16	
	<b>Material</b>	Body : Aluminum
		Roller : PE
	<b>Q'ty/Bundle</b>	6ea

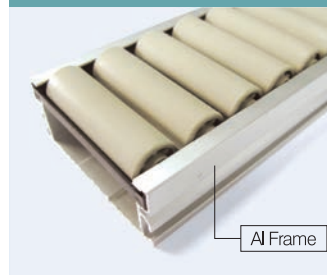
<b>GPR7021BFS-2-AL</b>	Silent Roller, Pitch: 21	
	<b>Material</b>	Body : Aluminum
		Roller : Urethane
	<b>Q'ty/Bundle</b>	6ea

# ROLLER TRACKS

# ROLLER TRACKS

Unit : mm

**GPR8523S-AL** Silent Roller, Pitch: 22.5

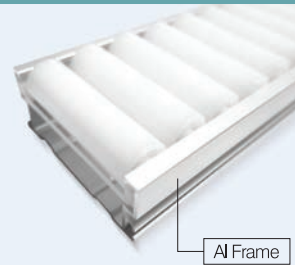

<b>Material</b>	Body : Aluminum
	Roller : PE
<b>Q'ty/Bundle</b>	4ea

Al Frame

**GPR8545B-AL** Silent Roller, Pitch: 45



<b>Material</b>	Body : Aluminum
	Roller : PE
<b>Q'ty/Bundle</b>	4ea

Al Frame

**GPR8545HA-AL** Silent Roller, Pitch: 45

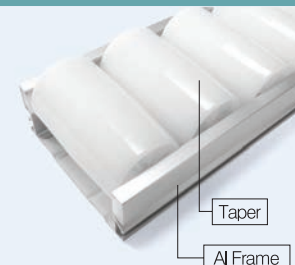

<b>Material</b>	Body : Aluminum
	Roller : PE
<b>Q'ty/Bundle</b>	4ea

Taper  
Al Frame

**GPR1021BFS-AL** Silent Roller, Pitch: 21



Utility Model (Patent)

<b>Material</b>	Body : Aluminum
	Roller : Urethane
<b>Q'ty/Bundle</b>	4ea

Al Frame

## STANDARD ROLLER TRACK

**GP-3533B** Pitch : 33



<b>Material</b>	Body : GI
	Roller : PE
<b>Q'ty/Bundle</b>	10ea

**NEW GP-4035BS** Pitch : 35

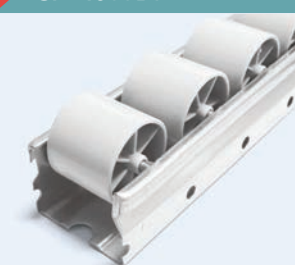

<b>Material</b>	GI Steel / PE
<b>Q'ty/Bundle</b>	10eaw

**GP-4036A** Pitch: 36



<b>Material</b>	Body : GI
	Roller : PE
<b>Q'ty/Bundle</b>	10ea

**GP-4036B** Pitch: 36



<b>Material</b>	Body : GI
	Roller : PE
<b>Q'ty/Bundle</b>	10ea

**GP-4040A** Pitch: 40



<b>Material</b>	Body : GI
	Roller : PE
<b>Q'ty/Bundle</b>	10ea

**GP-4040B** Pitch: 40



<b>Material</b>	Body : GI
	Roller : PE
<b>Q'ty/Bundle</b>	10ea

Unit : mm

**GP-4050C** Pitch: 50



<b>Material</b>	Body : GI
	Roller : PE
<b>Q'ty/Bundle</b>	10ea

**GP-4050D** Pitch: 50



<b>Material</b>	Body : Aluminum
	Body : GI
<b>Q'ty/Bundle</b>	10ea

**GP4025M** Pitch: 25



<b>Material</b>	Body : GI
	Roller : PE
<b>Q'ty/Bundle</b>	10ea

**GP6016S** Pitch: 16



<b>Material</b>	Body : GI
	Roller : PE
<b>Q'ty/Bundle</b>	10ea

**GP6033B** Pitch: 33



<b>Material</b>	Body : GI
	Roller : PE
<b>Q'ty/Bundle</b>	10ea

**GP6033HA** Pitch: 33



Taper

<b>Material</b>	Body : GI
	Roller : PE
<b>Q'ty/Bundle</b>	6ea

**GP7050BF** Pitch: 50



<b>Material</b>	Body : GI
	Roller : TPV
<b>Q'ty/Bundle</b>	6ea

**GP8543B** Pitch: 43



<b>Material</b>	Body : GI
	Roller : PE
<b>Q'ty/Bundle</b>	4ea

**GP8525M** Pitch: 25



<b>Material</b>	Body : GI
	Roller : PE
<b>Q'ty/Bundle</b>	4ea

## STS COVERED ROLLER TRACK

Unit : mm

**GPR4040SR-GI** STS Covered Roller, Pitch: 40



<b>Material</b>	Body : GI
	Roller : STS+PE
<b>Q'ty/Bundle</b>	10ea

**GPR8545SR-AL** Recycle STS Covered Roller Track, Pitch: 45

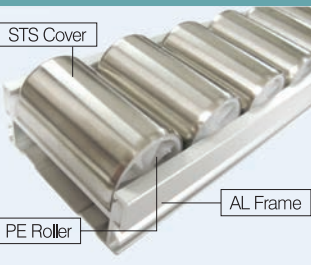

<b>Material</b>	Body : Aluminum
	Roller : STS+PE
<b>Q'ty/Bundle</b>	4ea

**GP8550SR** STS Covered Roller, Pitch: 50



<b>Material</b>	Body : GI
	Roller : STS+PE
<b>Q'ty/Bundle</b>	4ea

**PR-01** Pipe Roller -L



<b>Material</b>	PE
<b>Weight</b>	0.031kg
<b>Q'ty/Box</b>	150pcs

**PR-02** Pipe Roller - S



<b>Material</b>	PE
<b>Weight</b>	0.022kg
<b>Q'ty/Box</b>	210pcs

**SR-40** Stop Roller



<b>Material</b>	PE
<b>Weight</b>	0.012kg
<b>Q'ty/Box</b>	450pcs

**SR-60A** Stop Roller



<b>Material</b>	Aluminum
<b>Weight</b>	0.046kg
<b>Q'ty/Box</b>	80pcs

**SR-85A** Stop Roller



<b>Material</b>	Aluminum
<b>Weight</b>	0.078kg
<b>Q'ty/Box</b>	40pcs

Surface Treatment-WZ

Unit : mm

**DR-40R** Decelerating Roller



<b>Material</b>	Body : GI
	Roller : STS+PE
	Q'ty/Bundle 10ea

Maximum Box Brake Weight Per Slope					Remark
$\theta=1.5^\circ$	$\theta=2.0^\circ$	$\theta=2.5^\circ$	$\theta=3.0^\circ$	$\theta=3.5^\circ$	
32Kg	25Kg	6 Kg	4 Kg	2.5 Kg	Roller Load = 1.4Kgf/ea
-	32Kg	12Kg	9 Kg	5 Kg	

**NEW ACA-308B** Decelerator

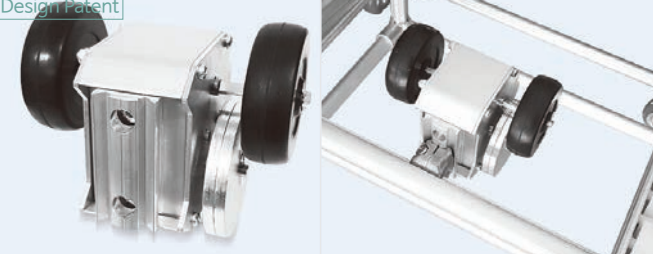

· Range of braking : 10Kgf  
· Q'ty/Box : 6set

※ ACA-308B is sold basically

PART NO.	ACA-308A	ACA-308B	ACA-308C
<b>Size</b>	Ø 50	Ø 60	Ø 70
<b>Weight (g/Set)</b>	794g	864g	940g
<b>Torque (gf.cm)</b>	160~180gf.cm	280gf.cm	380~400gf.cm

※ Sold separately

W-50	W-60	W-70
Ø 50 (75g)	Ø 60 (110g)	Ø 70 (148g)

## ROLLER TRACK MOUNTING BRKT (25 Series)

**GP-A25** Roller Mounting Bracket



<b>Material</b>	Steel
<b>Weight</b>	0.082kg
<b>Q'ty/Box</b>	90pcs

**GP-B25** Roller Mounting Bracket / Tab Stop



<b>Material</b>	Steel
<b>Weight</b>	0.096kg
<b>Q'ty/Box</b>	60pcs

**GP-E25** Roller Mounting Bracket / Center Support



<b>Material</b>	Steel
<b>Weight</b>	0.057kg
<b>Q'ty/Box</b>	120pcs

## ROLLER TRACK MOUNTING BRKT (35 Series)

Surface Treatment-WZ  
Unit : mm

**GP-A35** Roller Mounting Bracket



<b>Material</b>	Steel
<b>Weight</b>	0.111kg
<b>Q'ty/Box</b>	80pcs

**GP-B35** Roller Mounting Bracket / Tap Stop



<b>Material</b>	Steel
<b>Weight</b>	0.132kg
<b>Q'ty/Box</b>	60pcs

**GP-B35-1** Roller Mounting Bracket / Tap Stop



<b>Material</b>	Steel
<b>Weight</b>	0.240kg
<b>Q'ty/Box</b>	70pcs

**GP-B35-33** Roller Mounting Bracket / Tap Stop



<b>Material</b>	Steel
<b>Weight</b>	0.132kg
<b>Q'ty/Box</b>	60pcs

Bracket for assembling with upper Joint

**GP-C35** Roller Track Union



<b>Material</b>	Steel
<b>Weight</b>	0.148kg
<b>Q'ty/Box</b>	60pcs

**GP-D35** Roller Mounting Bracket / Drop Stop



<b>Material</b>	Steel
<b>Weight</b>	0.130kg
<b>Q'ty/Box</b>	70pcs

**GP-E35** Roller Mounting Bracket / Center Support



<b>Material</b>	Steel
<b>Weight</b>	0.064kg
<b>Q'ty/Box</b>	120pcs

**GP-E35-A12** Roller Mounting Bracket / Center Support

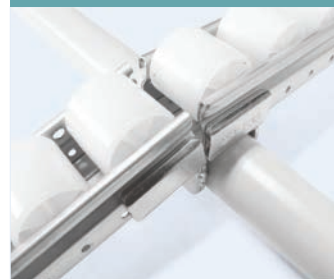

<b>Material</b>	Steel
<b>Weight</b>	0.117kg
<b>Q'ty/Box</b>	60pcs

**GP-HN35** Roller Track Union



<b>Material</b>	Steel
<b>Weight</b>	0.175kg
<b>Q'ty/Box</b>	36pcs

**GP-M35** Roller Mounting Bracket



<b>Material</b>	Steel
<b>Weight</b>	0.210kg
<b>Q'ty/Box</b>	30pcs

Surface Treatment-WZ  
Unit : mm

**GP-VA35** Roller Mounting Bracket



<b>Material</b>	Steel
<b>Weight</b>	0.190kg
<b>Q'ty/Box</b>	45pcs

The Roller track angle can be changed

## ROLLER TRACK MOUNTING BRKT (40 Series)

**GP-A** Roller Mounting Bracket



<b>Material</b>	Steel
<b>Weight</b>	0.141kg
<b>Q'ty/Box</b>	80pcs

**GP-A33** Roller Mounting Bracket



<b>Material</b>	Steel
<b>Weight</b>	0.142kg
<b>Q'ty/Box</b>	60pcs

**GP-APF** Roller Mounting Bracket



<b>Material</b>	Steel
<b>Weight</b>	0.124kg
<b>Q'ty/Box</b>	80pcs

Bracket for 30X30 profile

**GP-B** Roller Mounting Bracket / Tab Stop



<b>Material</b>	Steel
<b>Weight</b>	0.157kg
<b>Q'ty/Box</b>	60pcs

**GP-B33** Roller Mounting Bracket / Tab Stop



<b>Material</b>	Steel
<b>Weight</b>	0.173kg
<b>Q'ty/Box</b>	50pcs

# ROLLER TRACKS

Surface Treatment-WZ  
Unit : mm

**GP-B-1** Roller Mounting Bracket / Tab Stop



<b>Material</b>	Steel
<b>Weight</b>	0.174kg
<b>Q'ty/Box</b>	50pcs

**GP-B-1-33** Roller Mounting Bracket / Tab Stop



<b>Material</b>	Steel
<b>Weight</b>	0.174kg
<b>Q'ty/Box</b>	40pcs

**GP-C** Roller Track Union



<b>Material</b>	Steel
<b>Weight</b>	0.121kg
<b>Q'ty/Box</b>	80pcs

**GP-C-1** Roller Track Union / Center Support



<b>Material</b>	Steel
<b>Weight</b>	0.170kg
<b>Q'ty/Box</b>	40pcs

**GP-C-1-33** Roller Track Union / Center Support



<b>Material</b>	Steel
<b>Weight</b>	0.170kg
<b>Q'ty/Box</b>	32pcs

**GP-CN** Roller Track Union



<b>Material</b>	Steel
<b>Weight</b>	0.232kg
<b>Q'ty/Box</b>	36pcs

**GP-DF** Roller Mounting Bracket / Drop Stop



<b>Material</b>	Steel
<b>Weight</b>	0.194kg
<b>Q'ty/Box</b>	50pcs

**GP-DF-40** Roller Mounting Bracket / Drop Stop



<b>Material</b>	Steel
<b>Weight</b>	0.220kg
<b>Q'ty/Box</b>	30pcs

**GP-DFJ** Roller Mounting Bracket



<b>Material</b>	Steel
<b>Weight</b>	0.194kg
<b>Q'ty/Box</b>	50pcs

**GP-DN** Roller Mounting Bracket / Drop Stop



<b>Material</b>	Steel
<b>Weight</b>	0.160kg
<b>Q'ty/Box</b>	70pcs

# ROLLER TRACKS

Surface Treatment-WZ  
Unit : mm

**GP-DN33** Roller Mounting Bracket / Drop Stop



<b>Material</b>	Steel
<b>Weight</b>	0.165kg
<b>Q'ty/Box</b>	70pcs

Bracket for assembling upper Joint

**GP-E** Roller Mounting Bracket / Center Support



<b>Material</b>	Steel
<b>Weight</b>	0.079kg
<b>Q'ty/Box</b>	100pcs

**GP-E-33** Roller Mounting Bracket / Center Support



<b>Material</b>	Steel
<b>Weight</b>	0.085kg
<b>Q'ty/Box</b>	100pcs

**GP-EN** Roller Mounting Bracket / Center Support



<b>Material</b>	Steel
<b>Weight</b>	0.217kg
<b>Q'ty/Box</b>	20pcs

**GP-F** Roller Mounting Bracket

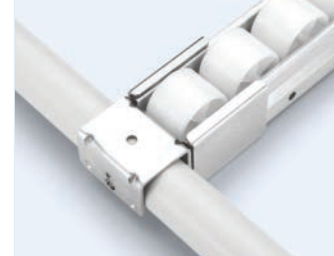

<b>Material</b>	Steel
<b>Weight</b>	0.175kg
<b>Q'ty/Box</b>	50pcs

**GP-F-33** Roller Mounting Bracket



<b>Material</b>	Steel
<b>Weight</b>	0.190kg
<b>Q'ty/Box</b>	36pcs

Bracket for assembling upper Joint

**GP-F-40** Roller Mounting Bracket

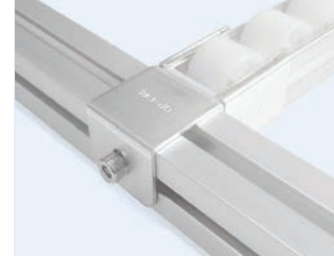

<b>Material</b>	Steel
<b>Weight</b>	0.200kg
<b>Q'ty/Box</b>	50pcs

Bracket for 40X40 profile

**GP-FC** Roller Mounting Bracket / Tap Stop



<b>Material</b>	Steel
<b>Weight</b>	0.200kg
<b>Q'ty/Box</b>	42pcs

Installation location could be changed by using Bolt easily

**GP-G** Roller Mounting Bracket / Tap Stop



<b>Material</b>	Steel
<b>Weight</b>	0.205kg
<b>Q'ty/Box</b>	40pcs

**GP-G-33** Roller Mounting Bracket



<b>Material</b>	Steel
<b>Weight</b>	0.220kg
<b>Q'ty/Box</b>	30pcs

Bracket for assembling upper Joint

# ROLLER TRACKS

Surface Treatment-WZ  
Unit : mm

**GP-HF** Roller Track Union



Material	Steel
Weight	0.230kg
Q'ty/Box	24pcs

**GP-HN** Roller Track Union



Material	Steel
Weight	0.279kg
Q'ty/Box	30pcs

**NEW GP-HN-33** Roller Track Mounting Bracket



Material	Steel
Weight	0.323kg
Q'ty/Box	30pcs

**GP-HP** Roller Track Union



Material	Steel
Weight	0.215kg
Q'ty/Box	24pcs

**GP-HS** Adjustable Roller to Slide Pipe Union

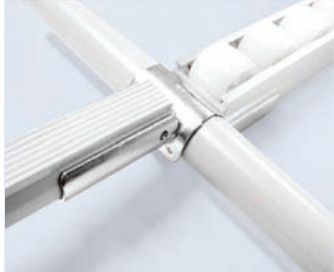

Material	Steel
Weight	0.200kg
Q'ty/Box	40pcs

upper side of 40 series roller and slide pipe side is same.

**GP-K** Roller Mounting Bracket



Material	Steel
Weight	-
Q'ty/Box	-

Bracket for recline by using Slide pipe into Roller

**GP-L** Roller Mounting Bracket



Material	Steel
Weight	0.144kg
Q'ty/Box	60pcs

**GP-L-33** Roller Mounting Bracket



Material	Steel
Weight	0.150kg
Q'ty/Box	60 pcs

Bracket for assembling upper Joint

**GP-LW** Roller Mounting Bracket



Material	Steel
Weight	0.144kg
Q'ty/Box	70 pcs

**GP-LW-33** Roller Mounting Bracket



Material	Steel
Weight	0.150kg
Q'ty/Box	70pcs

Bracket for assembling upper Joint

# ROLLER TRACKS

Surface Treatment-WZ  
Unit : mm

**GP-LWB** Roller Mounting Bracket / Tap Stop

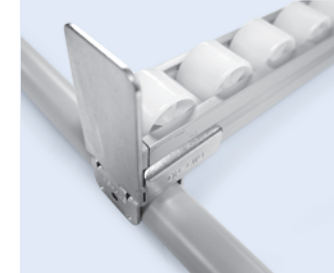

Material	Steel
Weight	0.180kg
Q'ty/Box	50pcs

**GP-M** Roller Mounting Bracket

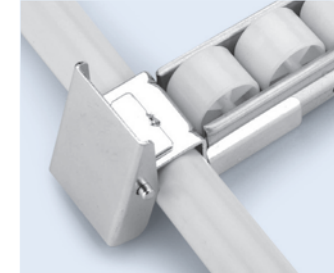

Material	Steel
Weight	0.239kg
Q'ty/Box	40 pcs

**GP-NA** Roller Mounting Bracket



Material	Steel
Weight	0.100kg
Q'ty/Box	80 pcs

**GP-NB** Roller Mounting Bracket / Tap Stop



Material	Steel
Weight	0.129kg
Q'ty/Box	60 pcs

**GP-SB** Absorber Mounting Bracket



Material	Steel
Weight	0.107kg
Q'ty/Box	70pcs

Bracket for Gas spring

**GP-VA40** Roller Mounting Bracket



Material	Steel
Weight	0.220kg
Q'ty/Box	35pcs

Roller Track angle can be changed

**GP-11** Adjustable Roller Union

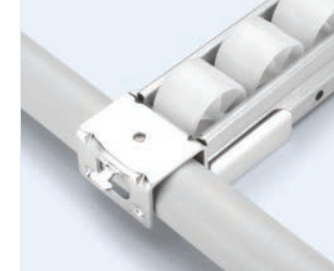

Material	Steel
Weight	0.131kg
Q'ty/Box	60 pcs

**GP-12** Adjustable Roller Union



Material	Steel
Weight	0.096kg
Q'ty/Box	180pcs

**GP-13** Adjustable Roller Union

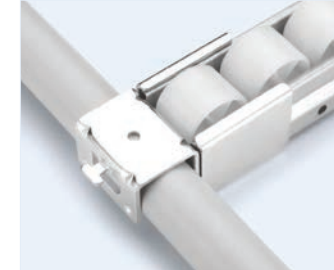

Material	Steel
Weight	0.173kg
Q'ty/Box	40pcs

**GP-14** Adjustable Roller Union





Material	Steel
Weight	0.096kg
Q'ty/Box	140pcs





## ROLLER TRACK MOUNTING BRKT (60 Series)

Surface Treatment-WZ  
Unit : mm

<b>GP-A60</b>	<b>Roller Mounting Bracket</b>						
	<table border="1"> <tr><td><b>Material</b></td><td>Steel</td></tr> <tr><td><b>Weight</b></td><td>0.164kg</td></tr> <tr><td><b>Q'ty/Box</b></td><td>60pcs</td></tr> </table>	<b>Material</b>	Steel	<b>Weight</b>	0.164kg	<b>Q'ty/Box</b>	60pcs
<b>Material</b>	Steel						
<b>Weight</b>	0.164kg						
<b>Q'ty/Box</b>	60pcs						

<b>GP-A60-33</b>	<b>Roller Mounting Bracket</b>						
	<table border="1"> <tr><td><b>Material</b></td><td>Steel</td></tr> <tr><td><b>Weight</b></td><td>0.164kg</td></tr> <tr><td><b>Q'ty/Box</b></td><td>50pcs</td></tr> </table> <p>Insert GAP-08 for preventing shaking</p>	<b>Material</b>	Steel	<b>Weight</b>	0.164kg	<b>Q'ty/Box</b>	50pcs
<b>Material</b>	Steel						
<b>Weight</b>	0.164kg						
<b>Q'ty/Box</b>	50pcs						

<b>GP-APF60</b>	<b>Roller Mounting Bracket</b>						
	<table border="1"> <tr><td><b>Material</b></td><td>Steel</td></tr> <tr><td><b>Weight</b></td><td>0.140kg</td></tr> <tr><td><b>Q'ty/Box</b></td><td>50pcs</td></tr> </table> <p>Bracket for 40X40 profile</p>	<b>Material</b>	Steel	<b>Weight</b>	0.140kg	<b>Q'ty/Box</b>	50pcs
<b>Material</b>	Steel						
<b>Weight</b>	0.140kg						
<b>Q'ty/Box</b>	50pcs						

<b>GP-B60</b>	<b>Roller Mounting Bracket / Tap Stop</b>						
	<table border="1"> <tr><td><b>Material</b></td><td>Steel</td></tr> <tr><td><b>Weight</b></td><td>0.250kg</td></tr> <tr><td><b>Q'ty/Box</b></td><td>30pcs</td></tr> </table>	<b>Material</b>	Steel	<b>Weight</b>	0.250kg	<b>Q'ty/Box</b>	30pcs
<b>Material</b>	Steel						
<b>Weight</b>	0.250kg						
<b>Q'ty/Box</b>	30pcs						

<b>GP-B60-1</b>	<b>Roller Mounting Bracket / Tap Stop</b>						
	<table border="1"> <tr><td><b>Material</b></td><td>Steel</td></tr> <tr><td><b>Weight</b></td><td>0.220kg</td></tr> <tr><td><b>Q'ty/Box</b></td><td>30pcs</td></tr> </table>	<b>Material</b>	Steel	<b>Weight</b>	0.220kg	<b>Q'ty/Box</b>	30pcs
<b>Material</b>	Steel						
<b>Weight</b>	0.220kg						
<b>Q'ty/Box</b>	30pcs						

<b>GP-B60-33</b>	<b>Roller Mounting Bracket / Tab Stop</b>						
	<table border="1"> <tr><td><b>Material</b></td><td>Steel</td></tr> <tr><td><b>Weight</b></td><td>0.250kg</td></tr> <tr><td><b>Q'ty/Box</b></td><td>20pcs</td></tr> </table> <p>Insert GAP-08 for preventing shaking</p>	<b>Material</b>	Steel	<b>Weight</b>	0.250kg	<b>Q'ty/Box</b>	20pcs
<b>Material</b>	Steel						
<b>Weight</b>	0.250kg						
<b>Q'ty/Box</b>	20pcs						

<b>GP-CN60</b>	<b>Roller Track Union</b>						
	<table border="1"> <tr><td><b>Material</b></td><td>Steel</td></tr> <tr><td><b>Weight</b></td><td>0.168kg</td></tr> <tr><td><b>Q'ty/Box</b></td><td>68pcs</td></tr> </table>	<b>Material</b>	Steel	<b>Weight</b>	0.168kg	<b>Q'ty/Box</b>	68pcs
<b>Material</b>	Steel						
<b>Weight</b>	0.168kg						
<b>Q'ty/Box</b>	68pcs						

<b>GP-D60</b>	<b>Roller Mounting Bracket / Drop Stop</b>						
	<table border="1"> <tr><td><b>Material</b></td><td>Steel</td></tr> <tr><td><b>Weight</b></td><td>0.205kg</td></tr> <tr><td><b>Q'ty/Box</b></td><td>40pcs</td></tr> </table>	<b>Material</b>	Steel	<b>Weight</b>	0.205kg	<b>Q'ty/Box</b>	40pcs
<b>Material</b>	Steel						
<b>Weight</b>	0.205kg						
<b>Q'ty/Box</b>	40pcs						

<b>GP-D60-33</b>	<b>Roller Mounting Bracket / Drop Stop</b>						
	<table border="1"> <tr><td><b>Material</b></td><td>Steel</td></tr> <tr><td><b>Weight</b></td><td>0.205kg</td></tr> <tr><td><b>Q'ty/Box</b></td><td>40pcs</td></tr> </table> <p>Insert GAP-08 for preventing shaking</p>	<b>Material</b>	Steel	<b>Weight</b>	0.205kg	<b>Q'ty/Box</b>	40pcs
<b>Material</b>	Steel						
<b>Weight</b>	0.205kg						
<b>Q'ty/Box</b>	40pcs						

<b>GP-DF60J</b>	<b>Roller Mounting Bracket</b>						
	<table border="1"> <tr><td><b>Material</b></td><td>Steel</td></tr> <tr><td><b>Weight</b></td><td>0.174kg</td></tr> <tr><td><b>Q'ty/Box</b></td><td>40pcs</td></tr> </table>	<b>Material</b>	Steel	<b>Weight</b>	0.174kg	<b>Q'ty/Box</b>	40pcs
<b>Material</b>	Steel						
<b>Weight</b>	0.174kg						
<b>Q'ty/Box</b>	40pcs						

Surface Treatment-WZ  
Unit : mm

<b>GP-E60</b>	<b>Roller Mounting Bracket / Center Support</b>						
	<table border="1"> <tr><td><b>Material</b></td><td>Steel</td></tr> <tr><td><b>Weight</b></td><td>0.095kg</td></tr> <tr><td><b>Q'ty/Box</b></td><td>100pcs</td></tr> </table>	<b>Material</b>	Steel	<b>Weight</b>	0.095kg	<b>Q'ty/Box</b>	100pcs
<b>Material</b>	Steel						
<b>Weight</b>	0.095kg						
<b>Q'ty/Box</b>	100pcs						

<b>GP-E60-33</b>	<b>Roller Mounting Bracket / Center Support</b>						
	<table border="1"> <tr><td><b>Material</b></td><td>Steel</td></tr> <tr><td><b>Weight</b></td><td>0.095kg</td></tr> <tr><td><b>Q'ty/Box</b></td><td>80pcs</td></tr> </table> <p>Insert GAP-08 for preventing shaking</p>	<b>Material</b>	Steel	<b>Weight</b>	0.095kg	<b>Q'ty/Box</b>	80pcs
<b>Material</b>	Steel						
<b>Weight</b>	0.095kg						
<b>Q'ty/Box</b>	80pcs						

<b>GP-EN60</b>	<b>Roller Track Union / Center Support</b>						
	<table border="1"> <tr><td><b>Material</b></td><td>Steel</td></tr> <tr><td><b>Weight</b></td><td>0.158kg</td></tr> <tr><td><b>Q'ty/Box</b></td><td>20pcs</td></tr> </table>	<b>Material</b>	Steel	<b>Weight</b>	0.158kg	<b>Q'ty/Box</b>	20pcs
<b>Material</b>	Steel						
<b>Weight</b>	0.158kg						
<b>Q'ty/Box</b>	20pcs						

<b>GP-EH60</b>	<b>Roller Mounting Bracket / Center Support</b>						
	<table border="1"> <tr><td><b>Material</b></td><td>Steel</td></tr> <tr><td><b>Weight</b></td><td>0.175kg</td></tr> <tr><td><b>Q'ty/Box</b></td><td>50pcs</td></tr> </table> <p>When using 40 series, like to use GP-60, IF USE GP-EH60, can be used same Roller Height</p>	<b>Material</b>	Steel	<b>Weight</b>	0.175kg	<b>Q'ty/Box</b>	50pcs
<b>Material</b>	Steel						
<b>Weight</b>	0.175kg						
<b>Q'ty/Box</b>	50pcs						

<b>GP-FC60</b>	<b>Roller Mounting Bracket</b>						
	<table border="1"> <tr><td><b>Material</b></td><td>Steel</td></tr> <tr><td><b>Weight</b></td><td>0.168kg</td></tr> <tr><td><b>Q'ty/Box</b></td><td>50pcs</td></tr> </table> <p>The installation location can be changed easily by using screw.</p>	<b>Material</b>	Steel	<b>Weight</b>	0.168kg	<b>Q'ty/Box</b>	50pcs
<b>Material</b>	Steel						
<b>Weight</b>	0.168kg						
<b>Q'ty/Box</b>	50pcs						

<b>GP-HN60</b>	<b>Roller Mounting Union</b>						
	<table border="1"> <tr><td><b>Material</b></td><td>Steel</td></tr> <tr><td><b>Weight</b></td><td>0.254kg</td></tr> <tr><td><b>Q'ty/Box</b></td><td>35pcs</td></tr> </table>	<b>Material</b>	Steel	<b>Weight</b>	0.254kg	<b>Q'ty/Box</b>	35pcs
<b>Material</b>	Steel						
<b>Weight</b>	0.254kg						
<b>Q'ty/Box</b>	35pcs						

<b>GP-L60</b>	<b>Roller Mounting Bracket</b>						
	<table border="1"> <tr><td><b>Material</b></td><td>Steel</td></tr> <tr><td><b>Weight</b></td><td>0.187kg</td></tr> <tr><td><b>Q'ty/Box</b></td><td>30pcs</td></tr> </table>	<b>Material</b>	Steel	<b>Weight</b>	0.187kg	<b>Q'ty/Box</b>	30pcs
<b>Material</b>	Steel						
<b>Weight</b>	0.187kg						
<b>Q'ty/Box</b>	30pcs						

<b>GP-L60W-33</b>	<b>Roller Mounting Bracket</b>						
	<table border="1"> <tr><td><b>Material</b></td><td>Steel</td></tr> <tr><td><b>Weight</b></td><td>0.187kg</td></tr> <tr><td><b>Q'ty/Box</b></td><td>30pcs</td></tr> </table> <p>Insert GAP-08 for preventing shaking</p>	<b>Material</b>	Steel	<b>Weight</b>	0.187kg	<b>Q'ty/Box</b>	30pcs
<b>Material</b>	Steel						
<b>Weight</b>	0.187kg						
<b>Q'ty/Box</b>	30pcs						

<b>GP-L60W</b>	<b>Roller Mounting Bracket</b>						
	<table border="1"> <tr><td><b>Material</b></td><td>Steel</td></tr> <tr><td><b>Weight</b></td><td>0.187kg</td></tr> <tr><td><b>Q'ty/Box</b></td><td>30pcs</td></tr> </table>	<b>Material</b>	Steel	<b>Weight</b>	0.187kg	<b>Q'ty/Box</b>	30pcs
<b>Material</b>	Steel						
<b>Weight</b>	0.187kg						
<b>Q'ty/Box</b>	30pcs						

<b>GP-L60WB</b>	<b>Roller Mounting Bracket / Tap Stop</b>						
	<table border="1"> <tr><td><b>Material</b></td><td>Steel</td></tr> <tr><td><b>Weight</b></td><td>0.220kg</td></tr> <tr><td><b>Q'ty/Box</b></td><td>40pcs</td></tr> </table>	<b>Material</b>	Steel	<b>Weight</b>	0.220kg	<b>Q'ty/Box</b>	40pcs
<b>Material</b>	Steel						
<b>Weight</b>	0.220kg						
<b>Q'ty/Box</b>	40pcs						

Surface Treatment-WZ  
Unit : mm

Surface Treatment-WZ  
Unit : mm

**GP-M60** Roller Mounting Bracket



<b>Material</b>	Steel
<b>Weight</b>	0.280kg
<b>Q'ty/Box</b>	30pcs

**GP-E70-33** Roller Mounting Bracket / Center Support



<b>Material</b>	Steel
<b>Weight</b>	0.170kg
<b>Q'ty/Box</b>	50pcs

Insert GAP-08 for preventing shaking

**GP-EN70** Roller Mounting Bracket



<b>Material</b>	Steel
<b>Weight</b>	0.265kg
<b>Q'ty/Box</b>	24pcs

## ROLLER TRACK MOUNTING BRKT (70 Series)

**GP-A70** Roller Mounting Bracket



<b>Material</b>	Steel
<b>Weight</b>	0.204kg
<b>Q'ty/Box</b>	50pcs

**GP-A70-33** Roller Mounting Bracket

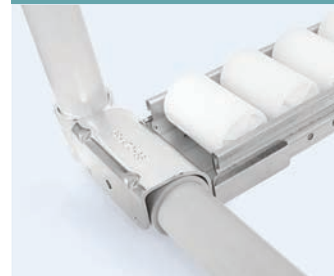

<b>Material</b>	Steel
<b>Weight</b>	0.204kg
<b>Q'ty/Box</b>	40pcs

Insert GAP-08 for preventing shaking

**GP-L70** Roller Mounting Bracket

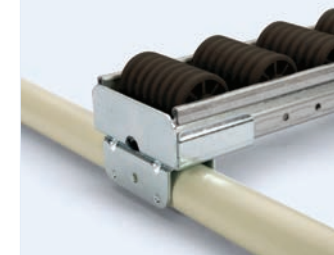

<b>Material</b>	Steel
<b>Weight</b>	0.209kg
<b>Q'ty/Box</b>	60pcs

**GP-L70-33** Roller Mounting Bracket



<b>Material</b>	Steel
<b>Weight</b>	0.209kg
<b>Q'ty/Box</b>	50pcs

Insert GAP-08 for preventing shaking

**GP-B70** Roller Mounting Bracket / Tap Stop



<b>Material</b>	Steel
<b>Weight</b>	0.280kg
<b>Q'ty/Box</b>	30pcs

**GP-B70-33** Roller Mounting Bracket



<b>Material</b>	Steel
<b>Weight</b>	0.280kg
<b>Q'ty/Box</b>	20pcs

Insert GAP-08 for preventing shaking

**GP-M70** Roller Mounting Bracket



<b>Material</b>	Steel
<b>Weight</b>	0.330kg
<b>Q'ty/Box</b>	20pcs

**GP-C70** Roller Track Union



<b>Material</b>	Steel
<b>Weight</b>	0.180kg
<b>Q'ty/Box</b>	36pcs

**GP-E70** Roller Mounting Bracket / Center Support



<b>Material</b>	Steel
<b>Weight</b>	0.170kg
<b>Q'ty/Box</b>	60pcs

## ROLLER TRACK MOUNTING BRKT (85 Series)

**GP-A85** Roller Mounting Bracket



<b>Material</b>	Steel
<b>Weight</b>	0.205kg
<b>Q'ty/Box</b>	40pcs

**GP-A85-33** Roller Mounting Bracket

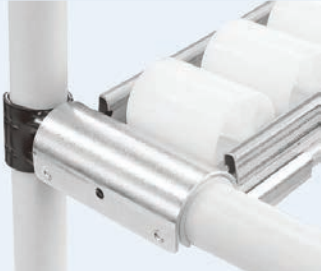

<b>Material</b>	Steel
<b>Weight</b>	0.205kg
<b>Q'ty/Box</b>	40pcs

Insert GAP-08 for preventing shaking

**GP-AN85** Roller Mounting Bracket / Drop Stop



<b>Material</b>	Steel
<b>Weight</b>	0.253kg
<b>Q'ty/Box</b>	40pcs

The Roller and Bracket height is same

**GP-B85** Roller Mounting Bracket / Tap Stop



<b>Material</b>	Steel
<b>Weight</b>	0.300kg
<b>Q'ty/Box</b>	30pcs

**GP-B85-1** Roller Mounting Bracket / Tab Stop



<b>Material</b>	Steel
<b>Weight</b>	0.318kg
<b>Q'ty/Box</b>	20pcs

**GP-B85-1-33** Roller Mounting Bracket / Tap Stop



<b>Material</b>	Steel
<b>Weight</b>	0.318kg
<b>Q'ty/Box</b>	15pcs

Insert GAP-08 for preventing shaking

**GP-B85-33** Roller Mounting Bracket / Tap Stop

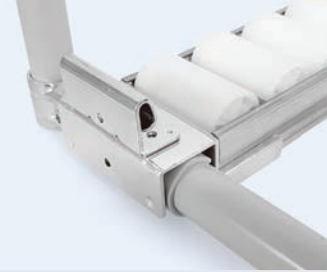

<b>Material</b>	Steel
<b>Weight</b>	0.300kg
<b>Q'ty/Box</b>	20pcs

Insert GAP-08 for preventing shaking

**GP-B85-2** Roller Mounting Bracket / Tap Stop

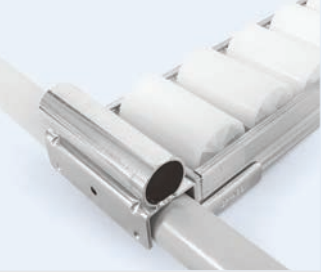

<b>Material</b>	Steel
<b>Weight</b>	0.300kg
<b>Q'ty/Box</b>	20pcs

**GP-C85-1** Roller Track Union / Center Support



<b>Material</b>	Steel
<b>Weight</b>	0.243kg
<b>Q'ty/Box</b>	20pcs

**GP-C85** Roller Track Union



<b>Material</b>	Steel
<b>Weight</b>	0.140kg
<b>Q'ty/Box</b>	70pcs

Surface Treatment-WZ  
Unit : mm

Surface Treatment-WZ  
Unit : mm

**GP-D85** Roller Mounting Bracket / Drop Stop



<b>Material</b>	Steel
<b>Weight</b>	0.235kg
<b>Q'ty/Box</b>	30pcs

**GP-E85** Roller Mounting Bracket / Center Support



<b>Material</b>	Steel
<b>Weight</b>	0.124kg
<b>Q'ty/Box</b>	80pcs

**GP-E85-33** Roller Mounting Bracket / Center Support



<b>Material</b>	Steel
<b>Weight</b>	0.124kg
<b>Q'ty/Box</b>	60pcs

Insert GAP-08 for preventing shaking

**GP-EN85** Roller Track Union / Center Support



<b>Material</b>	Steel
<b>Weight</b>	0.414kg
<b>Q'ty/Box</b>	12pcs

**GP-L85W** Roller Mounting Bracket



<b>Material</b>	Steel
<b>Weight</b>	0.264kg
<b>Q'ty/Box</b>	24pcs

**GP-L85W-33** Roller Mounting Bracket

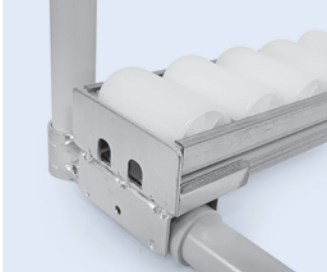

<b>Material</b>	Steel
<b>Weight</b>	0.265kg
<b>Q'ty/Box</b>	24ps

Insert GAP-08 for preventing shaking

**GP-M85** Roller Mounting Bracket

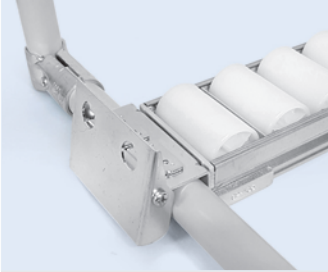

<b>Material</b>	Steel
<b>Weight</b>	0.410kg
<b>Q'ty/Box</b>	20pcs

**GP-M85-33** Roller Mounting Bracket

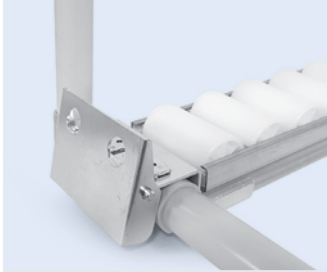

<b>Material</b>	Steel
<b>Weight</b>	0.442kg
<b>Q'ty/Box</b>	20pcs

Insert GAP-08 for preventing shaking

Surface Treatment-WZ  
Unit : mm

## ROLLER TRACK CAP

PRC-25A		Roller Track Cap	
	<b>Material</b>	ABS	
	<b>Weight</b>	0.002kg	
	<b>Q'ty/Box</b>	1,500pcs	
	Recycle Roller 25 series for AL Body		

PRC-35		Roller Track Cap	
	<b>Material</b>	ABS	
	<b>Weight</b>	0.004kg	
	<b>Q'ty/Box</b>	1,000pcs	
	Roller Track 35 Series for normal type		

PRC-40		Roller Track Cap	
	<b>Material</b>	ABS	
	<b>Weight</b>	0.005kg	
	<b>Q'ty/Box</b>	1,000pcs	
	Roller Track 40 Series for normal type		

PRC-40A		Roller Track Cap	
	<b>Material</b>	ABS	
	<b>Weight</b>	0.005kg	
	<b>Q'ty/Box</b>	1,000pcs	
	Recycle Roller 40 Series for AL Body		

PRC-40G		Roller Track Cap	
	<b>Material</b>	ABS	
	<b>Weight</b>	0.005kg	
	<b>Q'ty/Box</b>	1,000pcs	
	Recycle Roller 40 Series for GI Body		

PRC-60		Roller Track Cap	
	<b>Material</b>	ABS	
	<b>Weight</b>	0.006kg	
	<b>Q'ty/Box</b>	600pcs	
	Roller Track 60 Series for GI Body		

PRC-60A		Roller Track Cap	
	<b>Material</b>	ABS	
	<b>Weight</b>	0.006kg	
	<b>Q'ty/Box</b>	600pcs	
	Universal Roller UR-6067 type		

PRC-60B		Roller Track Cap	
	<b>Material</b>	ABS	
	<b>Weight</b>	0.006kg	
	<b>Q'ty/Box</b>	600pcs	
	Recycle Roller 60 Series for AL Body		

PRC-60G		Roller Track Cap	
	<b>Material</b>	ABS	
	<b>Weight</b>	0.006kg	
	<b>Q'ty/Box</b>	600pcs	
	Recycle Roller 60 Series for GI Body		

PRC-70A		Roller Track Cap	
	<b>Material</b>	ABS	
	<b>Weight</b>	0.008kg	
	<b>Q'ty/Box</b>	600pcs	
	Recycle Roller 70 Series for AL Body		

Surface Treatment-WZ  
Unit : mm

PRC-85A		Roller Track Cap	
	<b>Material</b>	ABS	
	<b>Weight</b>	0.010kg	
	<b>Q'ty/Box</b>	400pcs	
	Recycle Roller 85 Series for AL Body		

PRC-85G		Roller Track Cap	
	<b>Material</b>	ABS	
	<b>Weight</b>	0.010kg	
	<b>Q'ty/Box</b>	400pcs	
	Recycle Roller 85 Series for GI Body		

PRC-100A		Roller Track Cap	
	<b>Material</b>		
	<b>Weight</b>		
	<b>Q'ty/Box</b>		
	Recycle Roller 100 Series for AL Body		



**AMS, INC.** Advanced Mechatronics Solutions, Inc.

10030 Via de la Amistad, San Diego, CA 92154 ☎ +1 (619) 661-5985 🖨 +1 (619) 661-5995 @ [ams@ams-fa.com](mailto:ams@ams-fa.com)



**AMS do BRASIL** AMS Do Brasil Automacao Industrial LTDA de CV

Rua Laerte de Paiva, 344 Bairro Macuco Valinhos-SP-CEP 13279.451 ☎ +5 (19) 849-5555 @ [quote@ams-fa.com](mailto:quote@ams-fa.com)



**AMS de MEXICO** AMS Factory Automation de Mexico SA de CV de CV

Polígono Buenavista -- Calle Cementera Lote 9, Mz 8 Ejido Buenavista - Querétaro, Qro. 76225  
☎ +52 (442)312-0920 @ [mexico@ams-fa.com](mailto:mexico@ams-fa.com)